

- NOTES:
- PAVEMENT MARKINGS SHALL BE IN ACCORDANCE WITH THE ONTARIO TRAFFIC MANUAL (OTM), BOOK 11 (PAVEMENT, HAZARD AND DELINEATION MARKINGS) AND MANUAL OF UNIFORM TRAFFIC CONTROL DEVICES FOR CANADA (MUTCDC).
  - SIGNAGE SHALL BE IN ACCORDANCE WITH THE ONTARIO TRAFFIC MANUAL (OTM); BOOK 5 (REGULATORY SIGNS), BOOK 6 (WARNING SIGNS).
  - PAVEMENT MARKINGS TO ADHERE TO ONTARIO PROVINCIAL STANDARD SPECIFICATION (OPSS) 710.



KEY PLAN  
SCALE: N.T.S.

LEGEND

- EXISTING ROW
- PROPOSED WIDENING
- ASPHALT RESURFACING
- ASPHALT BOULEVARD
- ITEM REMOVAL

PAVEMENT MARKINGS LEGEND

1	SOLID YELLOW, 10cm
5	SOLID WHITE, 10cm
6	333 BROKEN WHITE, 10cm
13	SOLID WHITE, 30cm
20	SYMBOLS
[ ]	LIMITS OF MARKINGS

- NOTES:
- 333 DENOTES PAVEMENT MARKING SPACING AS 3m LINE, 3m GAP, 3m LINE
  - USE TO DENOTE PAVEMENT MARKING
  - USE TO DENOTE DURABLE PAVEMENT MARKING

MEDIAN HATCH MARKING  
DETAIL PER MUTCDC (FIG.C2-24)

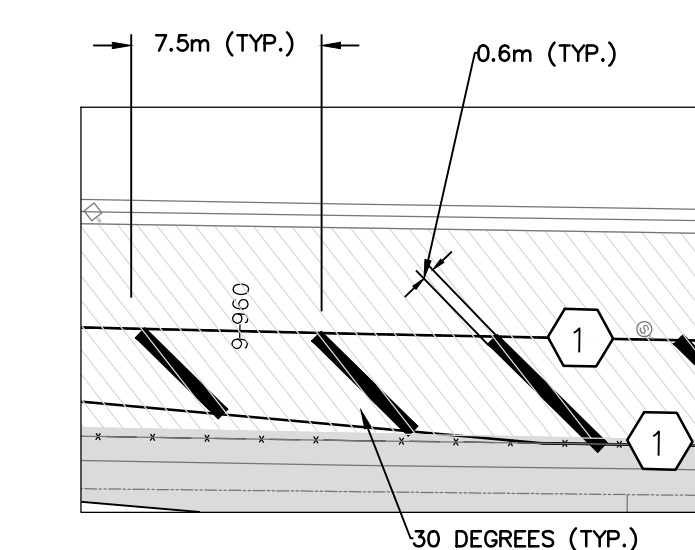

- NOTES:
- PAVEMENT MARKING TO BE DURABLE
  - PAINT COLOUR TO BE YELLOW

SCALE: N.T.S.

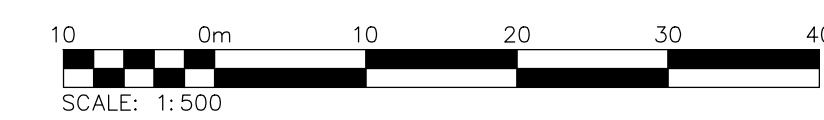

# LOYALIST PARKWAY (HIGHWAY 33)

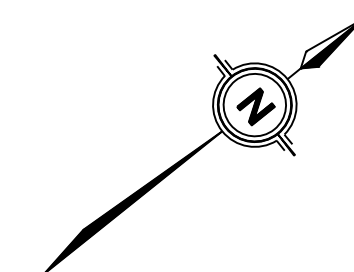
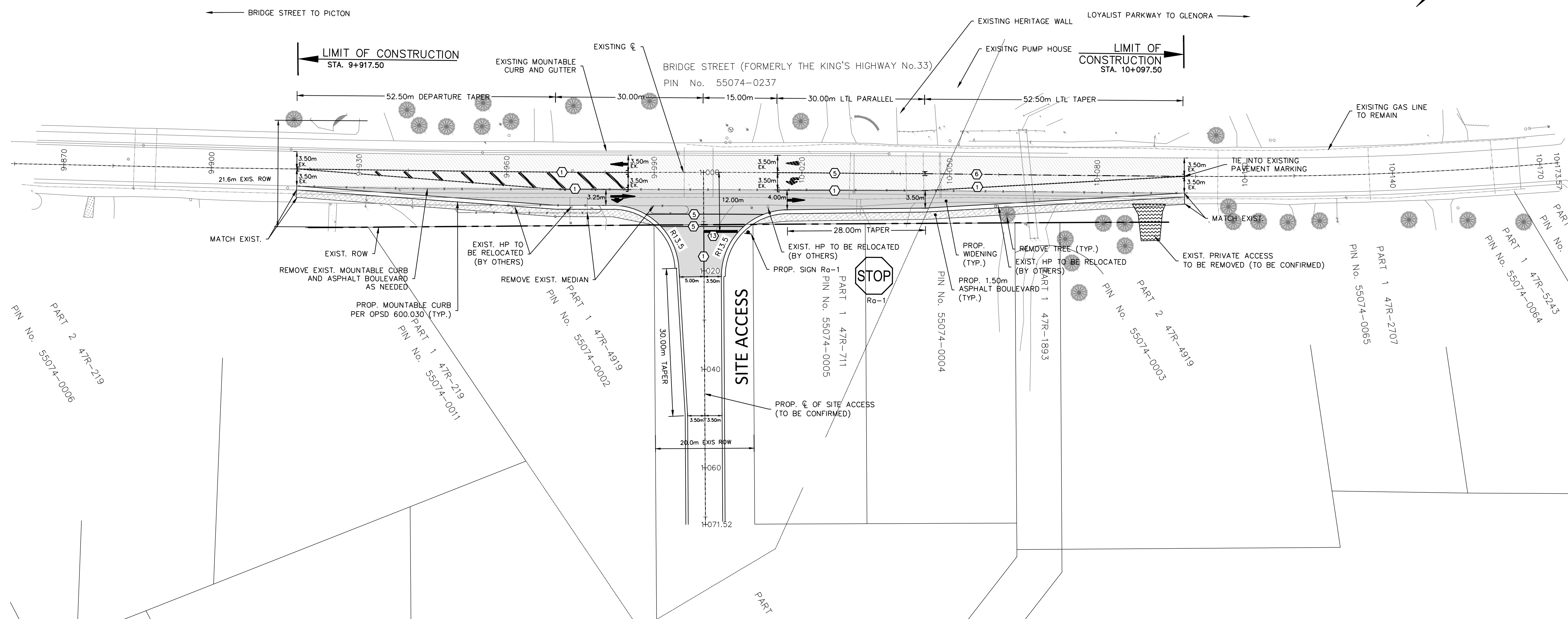

- THIS DRAWING IS THE EXCLUSIVE PROPERTY OF C.F. CROZIER & ASSOCIATES INC. AND THE REPRODUCTION OF ANY PART WITHOUT PRIOR WRITTEN CONSENT OF THIS OFFICE IS STRICTLY PROHIBITED.
- THE CONTRACTOR SHALL VERIFY ALL DIMENSIONS, LEVELS, AND DATUMS ON SITE AND REPORT ANY DISCREPANCIES OR OMISSIONS TO THIS OFFICE PRIOR TO CONSTRUCTION.
- THIS DRAWING IS TO BE READ AND UNDERSTOOD IN CONJUNCTION WITH ALL OTHER PLANS AND DOCUMENTS APPLICABLE TO THIS PROJECT.
- DO NOT SCALE THE DRAWINGS.
- ALL EXISTING UNDERGROUND UTILITIES TO BE VERIFIED IN THE FIELD BY THE CONTRACTOR PRIOR TO CONSTRUCTION.

Town	
Project	

No.	ISSUE	DATE: MM/DD/YYYY
0	ISSUED DRAFT FOR DISCUSSION	APR/01/2022
1	ISSUED FOR REVIEW	OCT/03/2022

Engineer	
Engineer	
Project	

**FOR REVIEW**  
NOT TO BE USED FOR CONSTRUCTION

KING'S HIGHWAY 33 AND SITE ACCESS –  
12697 LOYALIST PARKWAY  
PRINCE EDWARD COUNTY

FUNCTIONAL DESIGN

**CROZIER**  
CONSULTING ENGINEERS

1 ADMIRAL BUILDING  
1 FIRST STREET, SUITE 200  
COLLINGWOOD, ON L3Y 1A1  
705-446-3510 T  
705-446-3520 F  
WWW.CFCROZIER.CA  
INFO@CFCROZIER.CA

Drawn By	P.D./I.Z.	Design By	P.D./I.Z.	Project	<b>5311-12697</b>	
Check By	A.F.	Check By	R.M.	Scale	1:500	
					Drawing	<b>T101</b>