

SITE STATISTICS

LOT AREA	12,210.00 sm.	131,427 sf
BUILDINGS FOOTPRINT	2,614.13 sm.	28,138 sf
EAST BUILDING	1,141.08 sm.	12,282 sf
WEST BUILDING	1,369.20 sm.	14,738 sf
GARBAGE BUILDINGS	103.85 sm.	1,118 sf
COVERAGE	21%	
PAVED AREA	4,553.19 sm.	49,010 sf
LANDSCAPED AREA	4,925.14 sm.	53,014 sf
LANDSCAPED COVERAGE	40%	

AVERAGE GRADE	- m
LOWEST GRADE	- m
HIGHEST GRADE	- m
FFE	- m
BUILDING HEIGHT	- m

PROPOSED RESIDENTIAL UNITS - EAST BUILDING

	1BR	2BR	Total
LEVEL 1	8 (2BF)	6 (1BF)	14
LEVEL 2	8 (1BF)	6 (1BF)	14
LEVEL 3	8 (1BF)	6 (1BF)	14
LEVEL 4	8 (1BF)	6 (1BF)	14
Total	32 (5BF)	24 (4BF)	56

PROPOSED RESIDENTIAL UNITS - WEST BUILDING

	1BR	2BR	Total
LEVEL 1	9 (3BF)	7 (1BF)	16
LEVEL 2	10 (1BF)	6 (1BF)	16
LEVEL 3	10 (1BF)	6 (1BF)	16
Total	29 (5BF)	19 (3BF)	48

VEHICLE PARKING

		Rate	
1BR	61	1.25	76
2BR	43	1.25	54
Residents B.F.			4

Total Parking Spaces Required: **130**

Parking Spaces Provided

Surface Parking	Including 4 B.F.	131
Total	Including 4 B.F.	131

PROPOSED BICYCLE PARKING

	Rate per Unit
OCCUPANT (Long Term)	
VISITOR (Short Term)	
Total	

AMENITY SPACE REQUIRED

60 Units	/ sm. Per Unit - Outdoor	
----------	--------------------------	--

AMENITY SPACE PROVIDED

Outdoor Amenity Space	
-----------------------	--

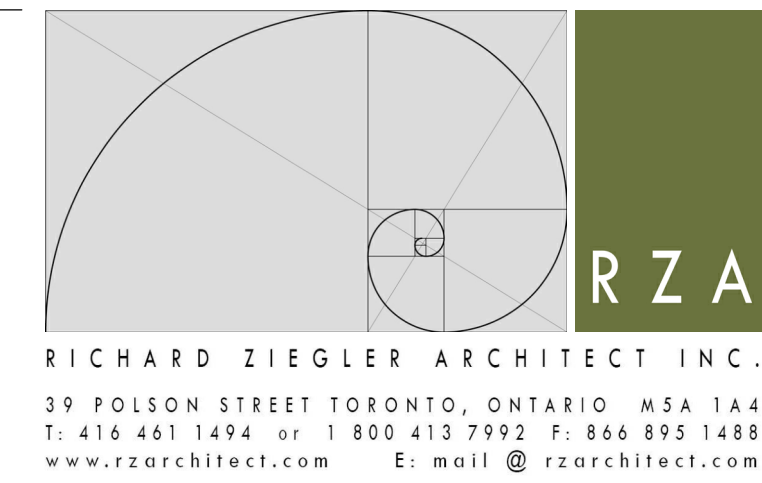

FOR INFORMATION EXCHANGE
 1/31/2023 4:25:05 PM

NO.	ISSUANCE	DATE
1	ISSUED FOR CLIENT REVIEW	2023.01.31

THE GENERAL CONTRACTOR SHALL CHECK AND VERIFY ALL DIMENSIONS AND REPORT ALL ERRORS AND OMISSIONS TO THE ARCHITECT. DO NOT SCALE THE DRAWINGS. DO NOT USE THIS DRAWING FOR CONSTRUCTION UNLESS SIGNED AND SEALED BY THE ARCHITECT.

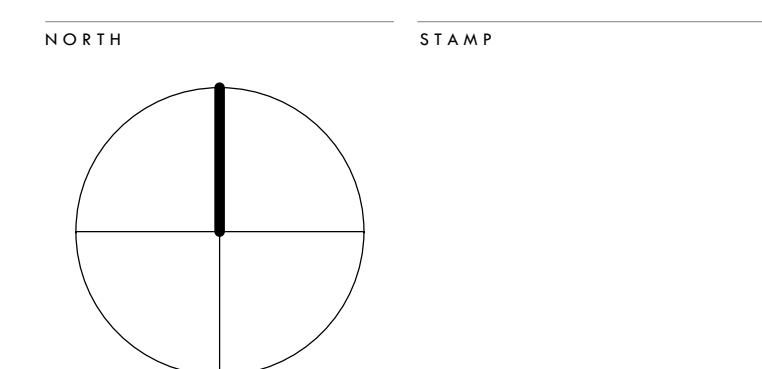

FIELDS OF WELLINGTON
 Block 15
 Wellington, ON

SITE PLAN

SCALE	1:250	PROJECT NUMBER	202219
DATE	1/31/2023 4:25:05 PM	CHECKED	REZ
DRAWN	SO	SHEET	REVISION

A.100x

FILE NAME: C:\Users\WZ\OneDrive\Documents\202319 - Wellington Low Rise 115 - Central Alignment
 PLOT DATE: 1/31/2023 4:25:05 PM