



GREER GALLOWAY
a division of Jp2g Consultants Inc.

Folkard Lane Multi-Residential Development Stormwater Management Report

January 2026

Prepared for:

**Cosmopolitan Homes
290 Lawrence Avenue West
Toronto, Ontario
M5M 1B3**

T: (416) 398-3600

Submitted by:

**Greer Galloway a division
of Jp2g Consultants inc.
2A-640 Cataraqui Woods Drive
Kingston, Ontario
K7P 2Y5**

**T: (613) 536-5420
F: (613) 548-3793
www.greergalloway.com**

Project No.: 25-5035A

Table of Contents

1.0 INTRODUCTION	2
1.1 Survey/Site Layout.....	2
1.2 Geotechnical Information.....	2
1.3 Standards and Guidelines.....	2
1.4 Design Criteria	3
2.0 EXISTING CONDITIONS.....	3
2.1 Existing Drainage Patterns	3
2.2 Existing Soil Conditions	4
3.0 PROPOSED DEVELOPMENT	4
3.1 Post-Development Drainage Patterns	5
3.2 Parameters.....	8
4.0 STORMWATER QUANTITY CONTROL AND QUALITY TREATMENT	8
4.1 Stormwater Quantity Treatment.....	9
4.2 Stormwater Quality Treatment.....	9
4.3 Major Overland Flow Routes	9
4.3.1 Subsurface Infrastructure Sizing.....	9
4.3.2 Grassed Conveyance Swale Sizing.....	10
5.0 INSPECTION AND MAINTENANCE	10
6.0 EROSION CONTROL.....	10
7.0 CONCLUSIONS AND RECOMMENDATIONS.....	11

Table of Tables

Table 1: Summary of Pre-Development Catchment Properties	3
Table 2: 49 Folkard Lane Changes in Land Use	5
Table 3: Summary of Pipe Capacity During the 100-Year Storm Event.....	9
Table 4: Summary of Swale Capacity During the 100-Year Storm Event.....	10

Table of Figures

Figure 1: Location of Residential Development, Folkard Lane.....	2
Figure 2: Existing Conditions Onsite.....	4

Table of Appendices

Appendix A – Drawings
Appendix B – Hydrologic Calculations
Appendix C – Hydraulic Calculations
Appendix D – Oil Grit Separator Information
Appendix E – Geotechnical Information

1.0 Introduction

Greer Galloway was retained by Cosmopolitan Homes to prepare a stormwater management report for a proposed site development. The site is located at 49 Folkard Lane in Picton, ON. This Stormwater Management Report has been prepared in support of a zoning by-law amendment application and site plan application for the proposed development.

This report is intended to examine the effects of the proposed development on stormwater quantity and quality and describes the proposed measures to mitigate the impact of the development through various control systems and best management practices.

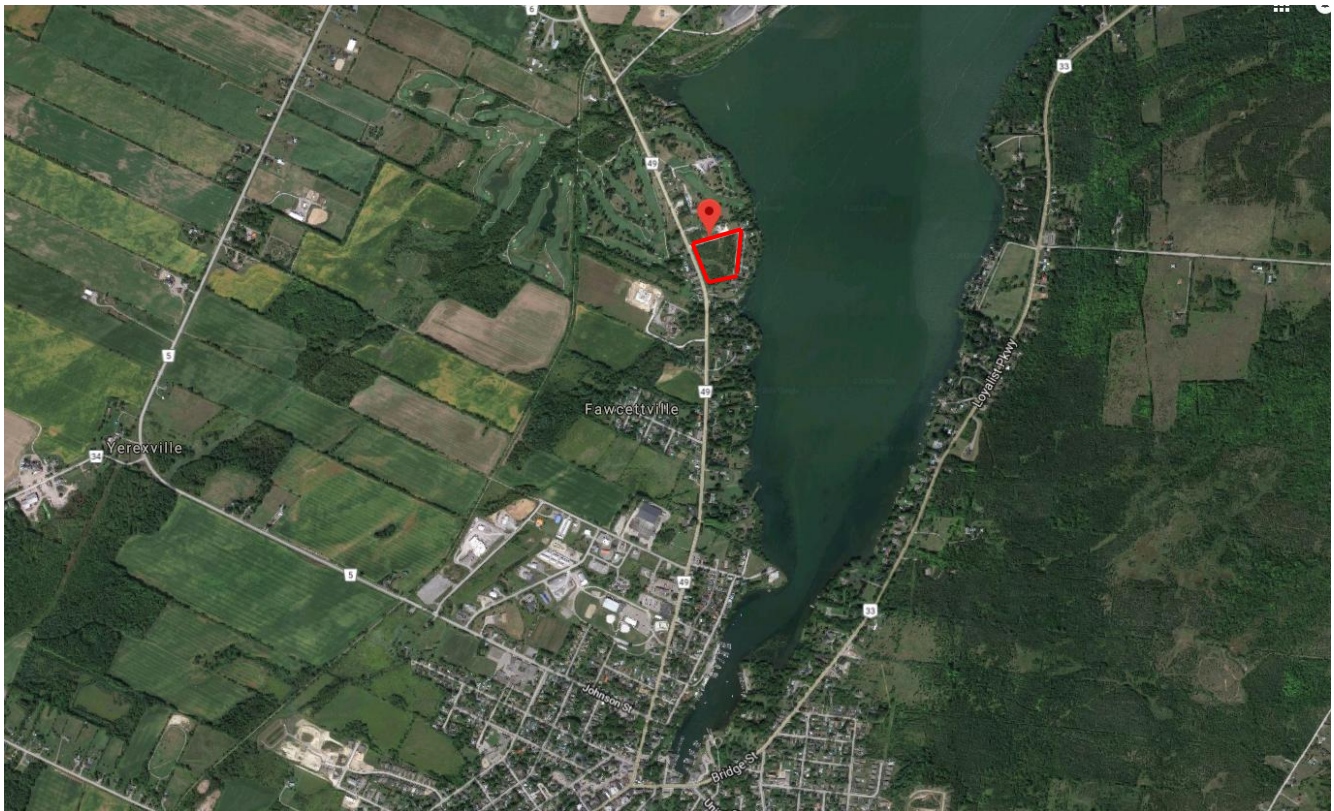

Figure 1: Location of Residential Development, Folkard Lane

1.1 Survey/Site Layout

A legal survey provided by the client, along with supplemental topographic survey conducted by Greer Galloway was used to delineate the existing drainage conditions of the development site. The site plan is included in Appendix A.

1.2 Geotechnical Information

Geotechnical information was provided in a geotechnical investigation report prepared by Cambium Inc. The information was used to identify approximate depth to bedrock on the site. The geotechnical report may be referred to in Appendix E.

1.3 Standards and Guidelines

The following standards and guidelines were consulted:

- Stormwater Management Practices Planning and Design Manual - Ministry of the Environment, 2003;
- MTO Drainage Management Manual – Ministry of Transportation, 1997;

- Stormwater Management Submission Guidelines – Quinte Conservation, 2012

1.4 Design Criteria

The design criteria for the stormwater management design are based on the requirements of Quinte Conservation and the Ministry of the Environment (MOE) and Prince Edward County. The key design criteria are summarized below:

- The development site is located in the Town of Picton's Intake Protection Zones 1 and 2 for the protection of the municipal drinking water supply. Level 1 protection for stormwater runoff quality is required.
- The pre-development outlet for stormwater runoff is Picton Bay. As there is no risk of flooding the downstream receptor, no on-site storage is required. Safe conveyance of stormwater to the Bay is required.
- Sediment transference and erosion is to be mitigated during and after construction of the proposed site development.

2.0 Existing Conditions

Folkard Lane is located approximately 2.5 km north of Picton, Ontario. The development site can be accessed from Highway 49 by a private laneway with a gravel surface. The site has frontage along approximately 180 m of Highway 49 and along the entire 400 m length of Folkard Lane. The development lots in total have an approximate size of 3.22 ha and the current land use is a vacant primarily wooded area.

2.1 Existing Drainage Patterns

The site consists of an irregular-shaped land parcel at 49 Folkard Lane. The topography of the site is gently sloped towards the east (Picton Bay), and as a result the entirety of the property drains via sheet flow to the southeast. There is no single well-defined outlet existing on site, the runoff sheet flows over the adjacent residential properties and outlets to Picton Bay. There is one cross culvert on site to facilitate flow beneath Folkard Lane, see Figure 2.

The lots surrounding the proposed property are developed, primarily residential properties. There are several commercial properties to the north and south including a golf course located north of the site. There is an existing drainage culvert beneath Highway 49 that outlets near the west property line of the site. The Municipality intends to divert this culvert and connect the drainage course to the Municipal storm system infrastructure on Highway 49, as infrastructure improvements are forthcoming. Therefore, there does not appear to be any major contributing flows from the adjacent properties to site that will require management post-development. Analysis of the development has been limited to the development site itself.

There is one (1) pre-development drainage area that has been identified and shown on the pre-development drawing included in Appendix A. Individual catchment properties are summarized in Table 1.

Area 101 consists of the entirety of the site, 3.22 ha of primarily wooded area. The site sheet flows overland to the southeast and runoff outlets to Picton Bay.

Table 1: Summary of Pre-Development Catchment Properties

Catchment	Area (ha)	C	% Impervious
101	3.22	0.27	6



Figure 2: Existing Conditions Onsite

2.2 Existing Soil Conditions

According to the borehole logs included in the Geotechnical Investigation Report completed by Cambium Inc., the development site consists mainly of sandy silt over shallow limestone bedrock which falls into Hydrologic soil group AB.

3.0 Proposed Development

The proposed development includes the construction of various types have townhouses totaling 111 units and 17 separate buildings. Also included in this development is a commercial building, which is intended to be used as a convenience store, in the northwest corner of the site. Included in the design plans are the addition of roadways and paved parking areas. The remaining footprint will be comprised of concrete sidewalks, as well as gravel, grass and landscaped areas. Post Development Drawings are included in Appendix A. Surface water runoff will be conveyed through a combination of sheet flow, swale, and subsurface infrastructure.

The construction of the new development will alter the existing land cover composition of the property. There will be an overall increase in the impervious surfaces. Table 2 summarizes the area changes in land use categories pre and post development:

Land Cover	Pre-Development	Post-Development	Change in Area
Grass	1.33 ha	1.24 ha	-0.09 ha
Wooded	1.70 ha	0.00 ha	-1.70 ha
Gravel	0.19 ha	0.00 ha	-0.19 ha
Roof	0.00 ha	0.93 ha	+0.93 ha
Asphalt	0.00 ha	1.05 ha	+1.05 ha
Total:	3.22 ha	3.22 ha	+0.00 ha

3.1 Post-Development Drainage Patterns

Quinte Conservation Authority was contacted, and it was determined that there were no flood flow management criteria required for the development site, as the site discharges directly into Picton Bay. It must be demonstrated that safe overland flow has been provided for the development site, under 100-year storm conditions. Management of stormwater will be facilitated primarily via grassed conveyance swales and subsurface storm infrastructure. As there is no existing well-defined outlet, a new outlet will be constructed along the east property line of the east portion of Lot 110 (Figure 2). The outlet will be a combination of a pipe outlet and an overflow swale that will receive all stormwater from the site and convey runoff to the Picton Bay.

The entirety of the site will ultimately outlet to the same location. However, the proposed grading plan will effectively divide the site into 31 subcatchment areas. Drawings with post-development stormwater areas are included in Appendix A. The subsurface infrastructure for each subcatchment has been sized to accommodate both a 5-year minor storm event as well as the 100-year major storm event. In the unlikely event of surcharging, excess flows will be handled by drainage swales that border the north, south and east sides of the property. See drawing C5 (Appendix A) for overland flow routes.

A1 is 0.24-hectare area comprised of the convenience store, its parking lot, the north section of the northern roadway, and some ditching. This area will direct all runoff into the ditch that runs along the north of the property and contribute to A2 via a 300mm culvert. The composite runoff coefficient is 0.63 with an imperviousness of 58%.

A2 is 0.07-hectare area which consists mainly of the northern ditching and a part of the northern road. The flows from this catchment are directed to that northern ditch and moves to catchment A6 via a 300mm culvert. This catchment has a composite runoff coefficient is 0.53 and imperviousness of 43.6%.

A3 is a 0.12-hectare catchment which consists of a section from the northern roadway, block 1 and 2 townhouses, as well as their corresponding concrete pathways, driveways and landscaped areas. Water from this catchment is directed into CB-1. The composite runoff coefficient is 0.65 and imperviousness is about 61.7%.

A4 is a 0.17-hectare area that primarily consists of the northern roadway, block 12 bungalow townhouses, as well as their corresponding driveways and pathways. All the runoff in this section will drain towards the CB-2, which also collects all the water from CB-1. The composite runoff coefficient for this area is 0.65 with imperviousness of 61.5%.

A5 is smaller 0.03-hectare section that covers some of block 12's eastern bungalow roof, paving and landscaped areas. It also has a small section of roadways in the north and east. This water all drains to CB-15. The composite runoff coefficient for this area is 0.87 with 96% imperviousness.

A6 is another small section of 0.04-hectare catchment. It does not have any roofing or concrete. It collects some water from the northeastern section of the roadway as well as from the driveways and grassed areas. The water enters the same ditch

system that has run through A1 and A2. This ditch leads to another 300mm culvert that connects to A12. The associated composite runoff coefficient is 0.58 with imperviousness of 50.7%.

A7 is located south of A3 and has an area of 0.11 hectares. This collects water from the south section of blocks 1 and 2 including the roadway. The catchment extends further south, covering more roadway and roofing near northern parts of block 3 townhouses. The water in this catchment drains along the curb southwards and into CB-6. The structure has a contributing stormwater runoff from the south side; CB-7. It will eventually convey all this water east into A14. The composite runoff coefficient for this area is 0.66 and is 61.9% impervious.

A8 is 0.10 ha area with 94% imperviousness. This area covers the remaining sections of block 2 houses as well as the roadway and intersection south of block 2. It also collects parts of block 6 townhouse roofing, pathways, and driveways. The water from this area flows into the CB-3. The composite runoff coefficient is 0.86.

A9 is a 0.04 ha area that consists primarily of the northern section of block 9 houses, driveways, concrete pathways, and small section of the roadway running south. Surface runoff from this area collects on the eastern side of the road into CBMH-1. This structure also directly collects water from the catch basins described earlier; CB-3 & CB-2. The associated composite runoff coefficient is 0.83 and imperviousness of 88.6%.

A10 is the largest catchment area with an area of 0.71 hectares. However, its runoff coefficient and imperviousness are relatively low at 0.50 and 38.5% respectively. The majority of this section is landscaped area on the east side of the development. However, there are some concrete pathways, as well as some roofing runoff from adjacent blocks in all directions. All the water in this area drains mostly via overland sheet flow and some shallow ditching towards the center of the grassed area and into a proposed ditch inlet manhole (DIMH-1).

A11 is a 0.16ha catchment with 89.2% imperviousness. It mainly consists of the roofing, concrete pathway, and driveways from block 16 and 17 housing that did not get collected by A10. However, it also collects a small section of block 15 roofing, as well as a section of the eastern road. The water in the south flows north along the curb, and northern areas convey water south along the curb. At the low point there is a structure that collects all of the described in addition to the water that arrives through pipes from catchment A10 and A5 (DIMH-1 and CB-15). Once collected the structure will convey the water into CBMH-14 located across the street in A26. The composite runoff coefficient is 0.83.

A12 is only 0.01ha and mainly catches the runoff from parts of the driveways on the east end as well as the grass ditch in between. The contribution of water previously collected in A1, A2, and A6 will continue through this catchment area southwards. There is another culvert, all this water enters draining into the A25 ditching. This catchment is 49.4% impervious with a composite runoff coefficient is 0.57.

A13 is a 0.03-hectare area that is located south of catchment A7. It collects the majority of the intersection runoff, east of block 3 housing. It also collects water from a small section of roofing of block 3 townhouses. The water drains to the southeast of the intersection into CB-7. This catch basin conveys its stormwater back north to A7's structure. The composite runoff coefficient for this site is 0.78 and imperviousness of 81.4%.

A14 is 0.05 hectares and covers the remaining section of block 6 townhouse roofing, driveways, pathways, and southern roadway. All the water drains to CB-4 which also collects the water that contributed to CB-6 from A7. The composite runoff coefficient for this area is 0.88 and the imperviousness is 96.4%.

A15 is 0.04 hectares and has a catch basin manhole located along the curb to the south limits. A section of the block 9 roofing, driveways, and sidewalks contribute to this structure, with very little grass area. In addition to this, the structure is responsible for receiving stormwater from 3 different pipe networks from the north, west and south. The areas that indirectly contribute to this structure are the following: A3, A4, A7-A9, A13, A14, A16- A21. The composite runoff coefficient for this area is 0.78 and it is 82.3% impervious.

A16 is 0.05 hectares and it covers a portion of block 4 roofing and the roadway just east of block 4. It also collects water from grassed areas west of block 7. This runoff drains into CB-11 near the southern intersection eventually contributing to CB-9. The imperviousness here is 78.5% and the runoff coefficient for this area is 0.76.

A17 is 0.05 hectares in area and collects water from the roadway, roofs, driveways and pathways northern side of block 7. It conveys all the collected water into the CB-5 which connects to CB-4 within catchment A14. The imperviousness here is 96.4% with a runoff coefficient of 0.88.

A18 has an area of 0.03 hectares, imperviousness of 67.6%, and a composite runoff coefficient of 0.69. This area catches the grassed sections east of block 7, as well a larger portion of the roadway. It drains to the CB-9 located at its southwestern limits.

A19 has an area of 0.08ha and catches a large amount of runoff from townhouses in block 10 as well as their corresponding driveways, pathways, and landscaped areas. It also collects runoff from the eastern half of the roadway that A18 could not catch. This water enters the CB-8 located in the southwest limits of the catchment area. The composite runoff coefficient is 0.79 and imperviousness is 83.5%.

A20 is 0.04 hectares in size and collects the remainder of block 7 roofing and features that were not caught by A17. The water then drains to CB-9 which is also catching water from A18 described earlier. CB-9 also has a lead coming in from both the south and the west which is getting water from A16 and A21. The composite runoff coefficient is 0.89 with 98.2% imperviousness.

A21 is 0.04 hectares as well and is located south of A20. It collects the stormwater runoff from the features within the northern section of block 8. After this it drains into CB-10 which ultimately conveys water north to CB-9 in A20. This area has an imperviousness of 95.9% and runoff coefficient of 0.87.

A22 is a 0.33-hectare catchment area that will collect water from the southwest portion of the site, including a portion of the western housing block. Stormwater runoff will flow into structure CB-13, which is located along the curb within the intersection with the southern roadway. The composite runoff coefficient is 0.81 and the area has an imperviousness of 86.6%.

A23 is 0.07 hectares, has a runoff coefficient of 0.71, and the imperviousness is 70.1%. This area has runoff entering CB-13 from parts of block 10 and block 11 pavement and roofing features. It also covers a section of roadway between block 8 and 11.

A24 is 0.11ha and is an L-shaped area south and east of A23 and A10. This area collects runoff from parts of the southern roadway as well some landscaped, roof, and paved areas of block 15. The water here enters CB-13 located on its western boundary along a curb. The runoff coefficient is 0.72 and there is 72.4% imperviousness here.

A25 is a 0.03ha catchment area and is located south of catchment A12. It continues to collect stormwater runoff from driveways and grassed areas on the eastern side of the property. The water is also conveyed through another ditch and through culverts under the driveways. The imperviousness for this catchment area is 38.9% with a 0.50 CRC value.

A26 is south of A25, indirectly catching all of the stormwater runoff from the previous ditching along the north as well. This is 0.02ha area with an imperviousness of 37.7% and a CRC value of 0.50. The water is drained into the CBMH-13 structure located within the ditching. This structure also receives water from CBMH-12 which itself has collected most runoff from northern and western pipe networks. From here the water is proposed to go to CBMH-14.

A27 is an easement located on the east of the map just south of A26. This is a 0.04ha area with some driveway and roadway sections on its western limits. However, it's primarily grassed and has an imperviousness of 7.6% and CRC of 0.30. This easement will have CBMH-14 located in its northwestern limits. The catch basin manhole will convey all the water it has

collected towards the east where there will be a proposed oil grit separator. This catchment area will also have an overflow swale located along its length in the unlikely event that the stormwater infrastructure is overloaded.

A28 is a 0.02-hectare catchment area south of A27. This area collects water from some driveways as well as previously contributing catchment areas to its south. Ditching and culverts are used to convey the water north to A27. The CRC here is 0.57 and there is 48.8% imperviousness.

A29 is located south of A28. Similarly, it also collects water from driveways on the east of the property as well as previously contributing catchment areas. It uses ditching and culverts to convey its water north to A28. This imperviousness here is 48.2%, CRC is 0.56, and area is 0.02 hectares.

A30 is 0.04 hectares and is located south of A29. The imperviousness is 50.5%, with a runoff coefficient of 0.58. The majority of its water will be from the previous catchment areas to the west, but it will also collect some runoff from the driveways within its limit. It uses ditching and culverts to bypass driveways and convey water north.

A31 is located at the south end of the development with a size of 0.33 hectares. This catchment area will collect water from the southern housing blocks, their driveways, landscaped areas, and sidewalks. It will also collect water from the roadway. Indirectly it will get contributing flows from CB -13 which corresponds to subcatchment area A24. The water is ultimately proposed to enter the swale to the southeast limits of the catchment area and then be conveyed northeast into A30. The imperviousness here is 59.6% and CRC is 0.64.

The proposed outlet for the site will run along the northern property part of lot 110, see Figure 2. A drainage ROW will need to be severed from the lot to allow for future maintenance of the outlet. The 750 mm outlet pipe will have a total length of approximately 60 m, passing through an OGS structure within the proposed easement, and then discharging to Picton Bay. The topography drops off very steeply towards the bay, and bedrock vary slopes to the surface at the outlet location of the pipe.

3.2 Parameters

Pre and post development peak flow rates have been calculated using the Rational Method. Runoff coefficients were taken from the MTO Drainage Management Manual and are as follows:

- Asphalt, concrete, roof areas (impervious) 0.90
- Grassed area, parkland, wooded areas (pervious) 0.25

For the purpose of this calculation, it was assumed that all walkways will be asphalt. It is acknowledged that they may be concrete but that this will not affect the composite runoff coefficients. It should also be noted that the high end of the range for runoff coefficients from the manual was utilized for these calculations. The resultant values are accordingly conservative in nature.

The composite runoff coefficients were used to calculate Time of Concentration for each of the post-development catchment areas. Times of Concentration (T_c) values have been calculated using the Bransby-Williams equation as well as the airport method. However, the minimum time of concentration was used for most of the smaller catchment areas of 15 minutes. Rainfall intensity values for storm events were obtained from the Ministry of Transportation IDF Curve Lookup for 49 Folkard Lane.

4.0 Stormwater Quantity Control and Quality Treatment

There is an overall increase in runoff between pre-and post-development conditions due to an increase in impervious surfaces. However, as the outlet for the site is Picton Bay, quantity control is not required for this development. Quality treatment must be provided to achieve Enhanced Treatment Level.

4.1 Stormwater Quantity Treatment

As quantity control is not required for this development, peak flows offsite will not be controlled, and no onsite storage methods are necessary.

4.2 Stormwater Quality Treatment

Runoff from this site will outlet directly into Picton Bay within the Intake Protection Zone, therefore an Enhanced Level of quality control is required. Quality treatment will be achieved through the installation of an oil grit separator. The OGS unit will be installed on the east side of Folkard Lane and all runoff leaving the site will pass through the unit. The suggested OGS unit for this site is the Stormceptor EFO8. Calculations and other associated information for this OGS structure have been appended to this report.

4.3 Major Overland Flow Routes

The subsurface infrastructure has been designed to convey a 100-year storm event. However, in the unlikely event of surcharging the runoff will be conveyed via overland flow and grassed swales. The swales have been designed to safely convey up to a 100-year storm event. The major flow routes are indicated in drawings C5 (Appendix A).

4.3.1 Subsurface Infrastructure Sizing

As noted above, all subsurface infrastructure has been designed to accommodate 100-year design flows. The table below summarizes the flows associated with the individual catchment areas and the impacts on the capacity of the associated pipe:

Catchment Area	From	To	Peak Flow 100 Year Storm (L/s)	Capacity (L/s)
A3	CB 1	CB 2	27.67	71.27
A4	CB 2	CBMH 1	63.97	100.11
A8	CB 3	CBMH 1	30.59	55.21
A9	CBMH 1	CBMH 2	102.42	162.79
A13	CB 7	CB 6	8.73	55.21
A7	CB 6	CB 4	32.41	106.67
A17	CB 5	CB 4	14.18	55.21
A14	CB 4	CBMH 2	59.44	100.11
A16	CB 11	CB 9	12.45	130.26
A21	CB 10	CB 9	10.87	55.21
A18/20	CB 9	CB 8	40.42	55.21
A19	CB 8	CBMH 2	59.86	100.11
A15	CBMH 2	DIMH 1	230.93	350.63
A10	DIMH 1	CBMH 12	341.24	401.02
A5	CB 15	CBMH 12	9.8	142.55
A11	CBMH 12	CBMH 13	386.97	452.66
A26	CB MH 13	CBMH 14	81.69	100.11
A23/24	CB 12	CB 14	42.11	55.21
A22	CB 14	CB 15	61.51	130.65
A31	CB 15	DITCHING/CBMH 14	186.97	210.17
A27	CBMH 14	OGS/OUTLET	689.75	845.05

A full hydraulic analysis of the pipe flows for both the 5-year and 100-year storm events is included in Appendix C.

4.3.2 Grassed Conveyance Swale Sizing

All of the main grassed conveyance swales and ditches must be able to convey the 100-year post development peak flows. It should be noted that the outlet overflow ditch will be a 0.3 m deep v-ditch. As subsurface infrastructure has been sized for the 1-100 year event, it is not expected that this ditch will regularly have flow. However, in the unlikely scenario where all the underground stormwater infrastructure is unable to convey a flow event, the water will overflow into this emergency ditch. This contingency will aid in ensuring that flooding of the site does not occur under extreme conditions. The table below summarizes the depths of the swales at the required peak flow rates:

Swale	Catchment	Peak Flow 100 Year Storm (L/s)	Capacity (L/s)
1	A1, A2, A6, A12, A25, A26	81.69	3557.23
2	A22-A24, A28-A31	200.06	2598.42
Outlet	A1-A31	689.75	387.87

Hydraulic analyses of the swales are included in Appendix C.

The swales are oversized to accommodate the unlikely potential for surcharging of the subsurface stormwater infrastructure. Under normal conditions, all flow from the swales and storm sewer are directed through an OGS structure prior outletting to Picton Bay.

5.0 Inspection and Maintenance

As per the MOE Stormwater Management Planning & Design Manual, for the first two years of operation the stormwater management system shall be inspected after every significant storm to ensure proper functionality. Subsequently the system should be inspected annually in order to identify potential maintenance issues. Potential maintenance and inspection activities for the stormwater management system include:

- Obstruction Removal – Obstructions and garbage should be cleaned from all swales, detention area and the outlet structure.
- Swales – Swales would be inspected regularly for signs of erosion. Any areas where erosion has occurred should be infilled and vegetated immediately.
- Vegetation Condition – annual weed control including the removal of invasive species like purple loose strife, the spread of which is undesirable or does not provide a useful treatment function. Weed removal should be done by hand without the use of herbicides. Grass should be maintained in a healthy condition and should be kept at a height of approximately 150 mm.

The maintenance schedule for the oil grit separator is included in Appendix D.

6.0 Erosion Control

During construction, a combination of light duty filter cloth, straw bale check dams, and other common measures will be applied to contain construction related suspended solids and other materials within the disturbed areas. All disturbed areas are to be bordered by light duty filter cloth, and straw bales or rip rap check dams are to be used where flows are concentrated. Vegetated surfaces will be established as rapidly as possible, and the physical barriers noted above will be continuously maintained until the vegetative cover is suitably established. Filter fabric will be placed under the grate of the catch basin structures until natural surfaces are restored.

7.0 Conclusions and Recommendations

Based on the stormwater analysis described in this report, The Greer Galloway Group Inc. draws the following conclusions and recommendations regarding the impact of the proposed development at 49 Folkard Lane:

- Uncontrolled post-development flow will be greater than pre-development flows due to changes in surface cover.
- Pre-development flows offsite do not need to be maintained as there is no risk of flooding the outlet (Picton Bay), therefore there is no quantity control required on site.
- Quality control will be achieved through grassed conveyance swales and an oil grit separator.

Respectfully Submitted,



Rob Asselstine, C.Tech
THE GREER GALLOWAY GROUP INC.
CONSULTING ENGINEERS



Kevin Hawley, P.Eng.
THE GREER GALLOWAY GROUP INC.
CONSULTING ENGINEERS



Appendix A Drawings

GENERAL

- 1. ALL WORKS TO BE COMPLETED IN ACCORDANCE WITH CURRENT ONTARIO BUILDING CODE, ONTARIO PROVINCIAL STANDARD SPECIFICATIONS AND DRAWINGS UNLESS SPECIFIED OTHERWISE.
2. PRIOR TO CONSTRUCTION, CONTRACTOR TO VERIFY ALL DIMENSIONS AND UTILITY LOCATES AND IDENTIFY POSSIBLE CONFLICTS.
3. ALL ENVIRONMENTAL PROTECTION MEASURES ARE THE RESPONSIBILITY OF THE CONTRACTOR.
4. ANY TRAFFIC SIGNS OR INFORMATION SIGNS REMOVED/DAMAGED DURING CONSTRUCTION ARE TO BE REPLACED AT THE CONTRACTORS EXPENSE.
5. ALL UTILITY POLES TO BE BRACED AS NECESSARY.
6. THE LOCATIONS OF UTILITIES ARE APPROXIMATE ONLY, AND THE EXACT LOCATION SHOULD BE DETERMINED BY CONSULTING THE MUNICIPAL AUTHORITIES AND UTILITY COMPANIES CONCERNED.
7. ALL WORK SHALL BE IN ACCORDANCE WITH RELEVANT CODES AND GUIDELINES.
8. ALL DRAWINGS AND ADDENDA ARE TO BE READ AS, AND IN CONJUNCTION WITH THE SPECIFICATIONS.
9. ALL MATERIALS SHALL BE INSTALLED AS SPECIFIED OR USING AN APPROVED EQUIVALENT.
10. CONTRACTOR IS RESPONSIBLE FOR VERIFICATION OF ALL DIMENSIONS BEFORE PROCEEDING WITH WORK.
11. ANY CHANGES MUST BE APPROVED BY THE ENGINEER.
12. ALL SERVICES THAT ARE TO BE REMOVED, REMOVE FROM THE MAIN TO PROPERTY LINE.
13. IF DEEMED SUITABLE BY CONTRACT ADMINISTRATION, EXCAVATED MATERIAL MAY BE USED TO COMPLETE TRENCH BACKFILLING, EXCEPT THAT NO BOULDERS SHALL BE ALLOWED. ALL COMPACTION OF TRENCH TO BE A MINIMUM OF 95% STANDARD PROCTOR DENSITY.
14. SIDEWALKS AND CURBS ARE TO BE DEPRESSED AT ALL EXISTING ENTRANCES. MAXIMUM SLOPE OF 1:20 AS PER 80.23 ACCESSIBILITY FOR ONTARIANS WITH DISABILITIES ACT (2005).
15. HDPE CULVERTS MAY ONLY BE INSTALLED IN SITUATIONS WHERE COVER EXCEEDS 300 MM. IN LOW COVER APPLICATIONS WHERE CSP MUST BE USED, A MINIMUM OF 150 MM GRANULAR 'A' BELOW ASPHALT SHALL BE INSTALLED AND A FROST TAPER BE USED AS PER OPSD 803.031 (NOV 2015).

TRAFFIC CONTROL

- 1. ALL TRAFFIC CONTROL/PEDESTRIAN SIGNING AS PER OTM. 80 OCT 7.

SITE WORKS

- 1. FOR AREAS OF EARTH SUBGRADE, GRANULAR DEPTHS ARE TO BE 150 MM GRANULAR A AND 300MM GRANULAR B TYPE 2. PROVIDE 3% CROSSFALL ON SUBGRADE.
2. CONCRETE CURB AS PER OPSD 600.040 (NOV 2012)
3. CONCRETE SHALL BE CLASS C2, 30 MPA 28 DAY STRENGTH, 19MM COARSE AGGREGATE NOMINAL MAXIMUM SIZE, 6.0% TO 8.0% AIR CONTENT.
4. CONCRETE MATERIALS AND PRODUCTION AS PER OPSS 350 (MAR 1998), 351 (NOV 2015), 353 (NOV 2016), 1301 (NOV 2007), 1302 (SEPT 1996) AND 1350 (NOV 2016).
5. BOULEVARDS AND LANDSCAPE AREAS TO BE FINISHED WITH 50MM OF TOPSOIL AND SEED, OR TO PRE-EXISTING CONDITION.
6. COMPACTION OF THE SUBGRADE FOR ASPHALT SHALL BE AS PER OPSS 501 (NOV 2017), COMPACTION TESTING MAY BE CARRIED OUT AT THE DISCRETION OF THE CONTRACT ADMINISTRATOR.
7. ANY GRANULAR MATERIAL INCORPORATED INTO THE WORK SHALL BE AS PER OPSS 1010 (NOV 2013) AND OPSS 314 (NOV 2016)
8. DEPTH OF GRANULAR 'A' UNDER NEW SIDEWALK SHALL BE 150 MM.
9. CONTRACTOR IS RESPONSIBLE FOR THE SHORING OF ALL EXCAVATIONS IF REQUIRED TO PROTECT ADJACENT INFRASTRUCTURE.
10. IN AREAS WHERE COMPACTION CANNOT BE ACHIEVED, THE CONTRACTOR SHALL USE NON-SHRINK FILL AS THE BACKFILL MATERIAL AS PER OPSS 1359 (NOV 2016).

GRADING

- 1. FINISHED SURFACES SHALL BE AT A MINIMUM GRADE OF 2% UNLESS OTHERWISE NOTED.
2. SLOPES IN LANDSCAPED AREAS SHALL NOT EXCEED 3:1.
3. ALL EXISTING ELEVATIONS AND GRADES ARE TO BE VERIFIED BY THE CONTRACTOR PRIOR TO GRADING.
4. ALL GROUND SURFACES SHALL BE GRADED TO PREVENT PONDING AND WITHOUT LOW AREAS EXCEPT WHERE APPROVED SWALE OR CATCHBASIN OUTLETS ARE PROVIDED.
5. THE CONTRACTOR IS RESPONSIBLE FOR REVIEWING PROPOSED GRADES WITH CONFLICTS REGARDING THE PROPOSED STRUCTURES.
6. SUB-GRADE SHALL BE GRADED AT A MINIMUM OF 2%, UNTIL A LOWER DITCH IS ENCOUNTERED OR THE EXISTING SURFACE DRAINS AWAY FROM THE SLOPED SUB-GRADE.
7. CONTRACTOR TO RESTORE ALL DISTURBED AREAS WITH 50MM OF TOPSOIL AS PER OPSS 804 OR TO PRE-EXISTING CONDITIONS.

REMOVE & REINSTATE

- 1. DRIVEWAY REMOVALS- LIMITS TO BE MARKED IN FIELD WITH CONTRACT ADMINISTRATOR AT PROPERTY LINE OR AS MARKED.
2. CONTRACTOR IS RESPONSIBLE FOR DISPOSAL OF EXCESS MATERIAL AS PER OPSS 510

SEDIMENT AND EROSION CONTROL NOTE

- 1. ALL EROSION AND SEDIMENT CONTROLS SHALL BE INSTALLED PRIOR TO CONSTRUCTION AND MONITORED AND MAINTAINED BY THE CONTRACTOR THROUGHOUT THE CONSTRUCTION PROCESS, UNTIL ALL DISTURBED AREAS HAVE BEEN RE-VEGETATED. THE TEMPORARY SEDIMENT AND EROSION CONTROL MEASURES MUST BE REMOVED ONCE THE SITE HAS BEEN STABILIZED/COMPLETED OF SITE WORKS.
2. ALL EROSION AND SEDIMENT CONTROL MEASURES SHALL BE INSPECTED AFTER EACH RAINFALL TO THE SATISFACTION OF THE CONTRACT ADMINISTRATOR.
3. ANY DISTURBED AREAS NOT SCHEDULED FOR FURTHER CONSTRUCTION WITHIN FORTY-FIVE (45) DAYS WILL BE PROVIDED WITH A SUITABLE TEMPORARY MULCH AND SEED COVER WITHIN SEVEN (7) DAYS OF COMPLETION.
4. REGARDLESS OF SITE SPECIFIC ITEMS DETAILED ON THE PLANS, THE CONTRACTOR SHALL INSTALL EROSION CONTROL MEASURES TO SUIT THE PROPOSED WORK METHODS TO CONTROL SEDIMENT FROM RUNNING OFF THE SITE PRIOR TO ANY DISTURBANCE.
5. ALL DISTURBED AREAS TO BE RESTORED TO ORIGINAL CONDITION OF BETTER UNLESS OTHERWISE SPECIFIED. REVEGETATION OF DISTURBED AREAS IS TO BE COMPLETED AS SOON AS POSSIBLE. RESTORATION SHALL PROVIDE A MINIMUM OF (i) TOPSOIL AND SEED/SOD.
6. ALL ROADS USED TO ACCESS THE SITE SHALL BE KEPT CLEAN TO THE SATISFACTION OF THE CONTRACT ADMINISTRATOR.

ENVIRONMENTAL

- 1. WHILE UNDERTAKING CLEARING, DEMOLITION, EXCAVATION OR CONSTRUCTION THE CONTRACTOR SHALL BE VIGILANT FOR THE POTENTIAL PRESENCE OF UNDERGROUND OIL TANKS, CONTAMINATED SOIL OR GROUNDWATER, BURIED WASTES OR ABANDONED WATER WELLS. IF ANY OF THE ABOVE ARE ENCOUNTERED OR SUSPECTED, THE OWNER SHALL ENSURE THAT ANY WASTES GENERATED BY SITE CLEAN-UPS ARE MANAGED IN ACCORDANCE WITH APPLICABLE LAWS AND STANDARDS.
2. CONSTRUCTION WASTES ARE NOT TO BE BURIED WITHIN THE PROPERTY THAT IS THE SUBJECT OF THIS AGREEMENT, AND THAT THE OWNER AND THEIR CONTRACTORS REPORT ALL SPILLS TO THE MINISTRY OF THE ENVIRONMENT'S SPILLS ACTION CENTRE (1-800-268-6060) AND TO PRINCE EDWARD COUNTY (J) FORTHWITH.

SIDEWALK

- 1. WHERE IN EARTH SUBGRADE GRANULAR DEPTHS TO BE 150 MM GRANULAR A AND 400MM GRANULAR B TYPE 2. PROVIDE 3% CROSSFALL ON SUBGRADE.
2. CONCRETE SHALL BE CLASS C2, 32 MPA 28 DAY STRENGTH, 19MM COARSE AGGREGATE NOMINAL MAXIMUM SIZE, 6.0% TO 8.0% AIR CONTENT.
3. CONCRETE MATERIALS AND PRODUCTION AS PER OPSS 350, 351, 352, 353, 1301, 1302 AND 1350.
4. LANDSCAPE AREAS TO BE FINISHED WITH 100MM OF TOPSOIL AND SEED, OR TO PRE-EXISTING CONDITION. THE SWALE WILL BE SODDED AS PER OPSS 803.
5. SIDEWALKS AND CURBS ARE TO BE DEPRESSED AT ALL EXISTING ENTRANCES. MAXIMUM SLOPE OF 1:20 AS PER 80.23 ACCESSIBILITY FOR ONTARIANS WITH DISABILITIES ACT (2005).

ASPHALT

- 1. PARKING LOT ASPHALT SHALL BE 60 MM HL3 SURFACE COURSE.
2. ASPHALT SHALL BE AS PER OPSS 310 (NOV 2017) AND OPSS 1150 (NOV 2010), THE PGAC SHALL BE 58-28.
3. A TOTAL OF 3 BULK ASPHALT SAMPLES SHALL BE TAKEN AS PER OPSS 310 (NOV 2017).

STORMWATER MANAGEMENT

- 1. SWALES TO BE SODDED AS PER OPSS 803 (APR 2018).
2. RODENT GATES TO BE INSTALLED AT ALL PIPE OUTLETS AS PER OPSS 405.

WATER

- 1. HYDRANTS SHALL BE MUELLER CENTURY OR APPROVED EQUIVALENT ANSI STANDARD C502-94.
2. WATERMANS SHALL BE PVC CLASS 150 AND CONFORM TO AWWA STANDARD C 900-94 OR DUCTILE IRON, CEMENT MORTAR LINED TO ANSI STANDARD C151/A21.51-02.
3. TRACER WIRE #8 AWG INSULATED COPPER WIRE TO BE INSTALLED ON ALL PVC WATERMANS AND PE SERVICE CONNECTIONS. TRACER WIRE SHALL BE GROUNDED TO EACH FITTING.
4. GATE VALVE SHALL BE MUELLER SUPER-SEAL RESILIENT SEAR OR APPROVED EQUIVALENT. CURB STOPS SHALL BE LOCATED 0.3m OFF THE PROPERTY LINE.
5. EXISTING WATER MAINS SHALL BE DIRECT TAPPED BY MUNICIPAL FORCES.

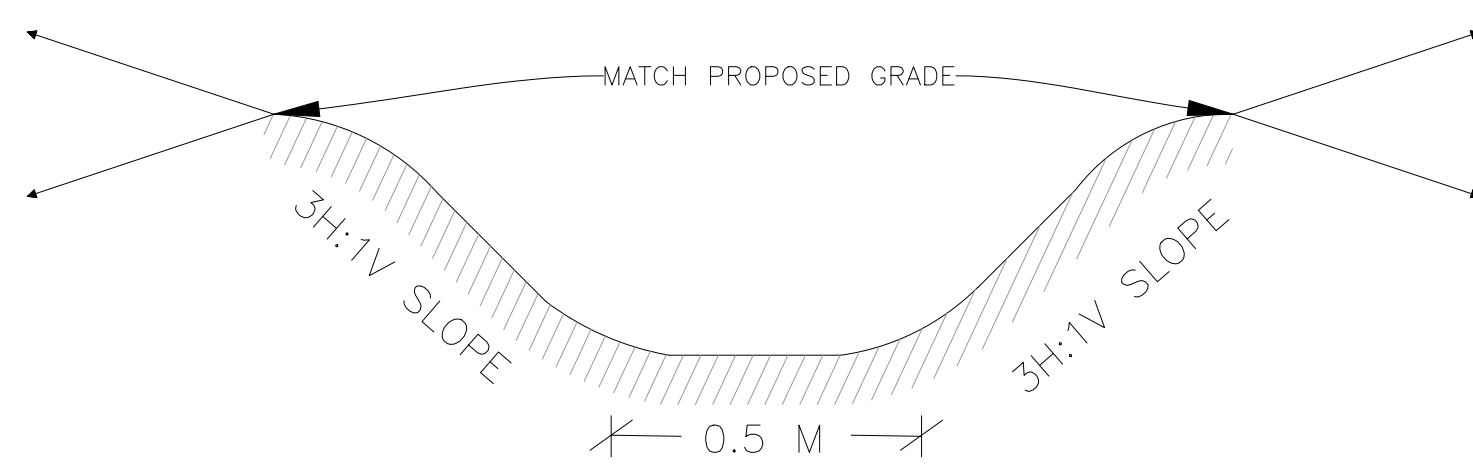

01 'TYPICAL' DITCH DETAIL SCALE: N.T.S.

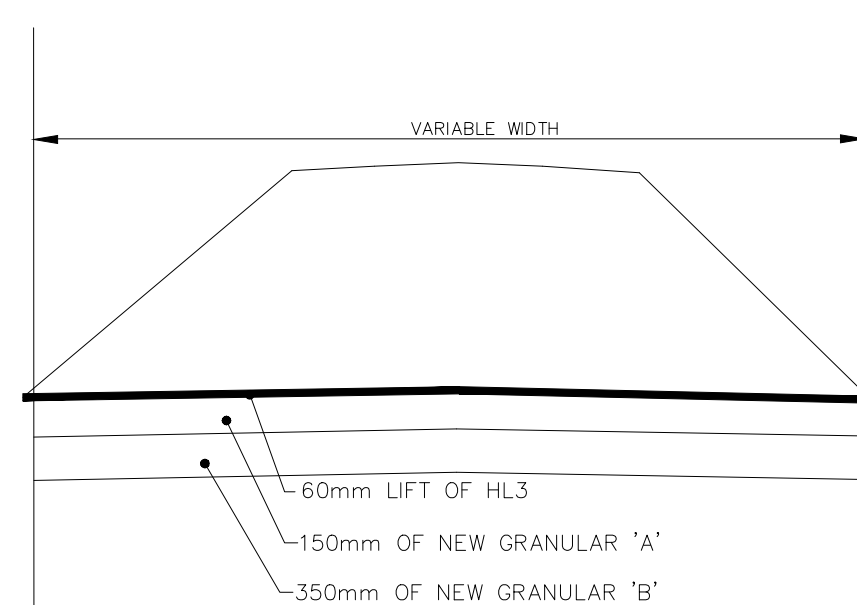

02 TYPICAL DRIVEWAY CROSS SECTION SCALE: N.T.S.

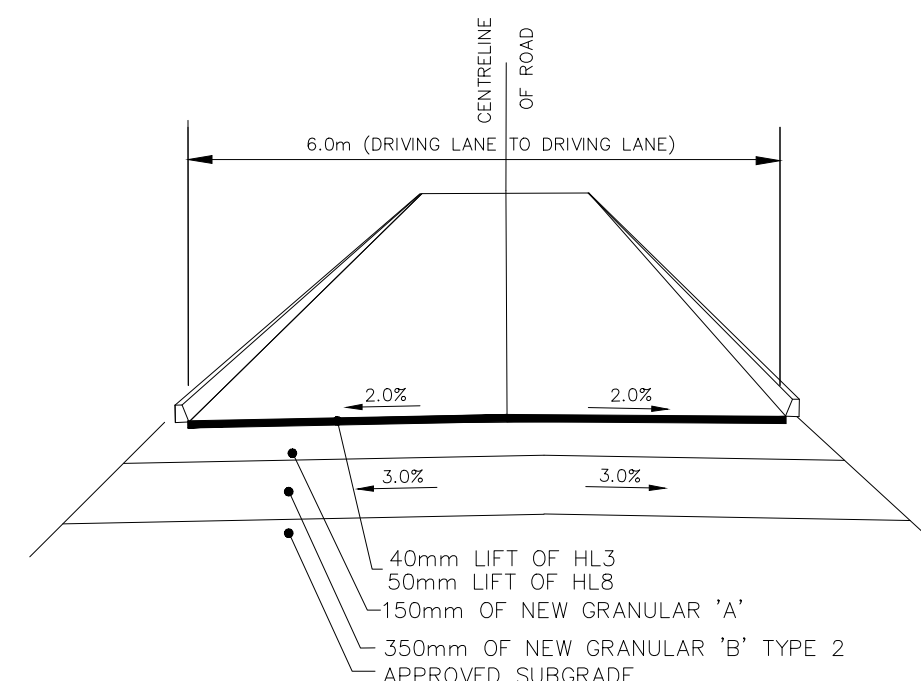

03 TYPICAL EXTERIOR ROAD DETAIL SCALE: N.T.S.

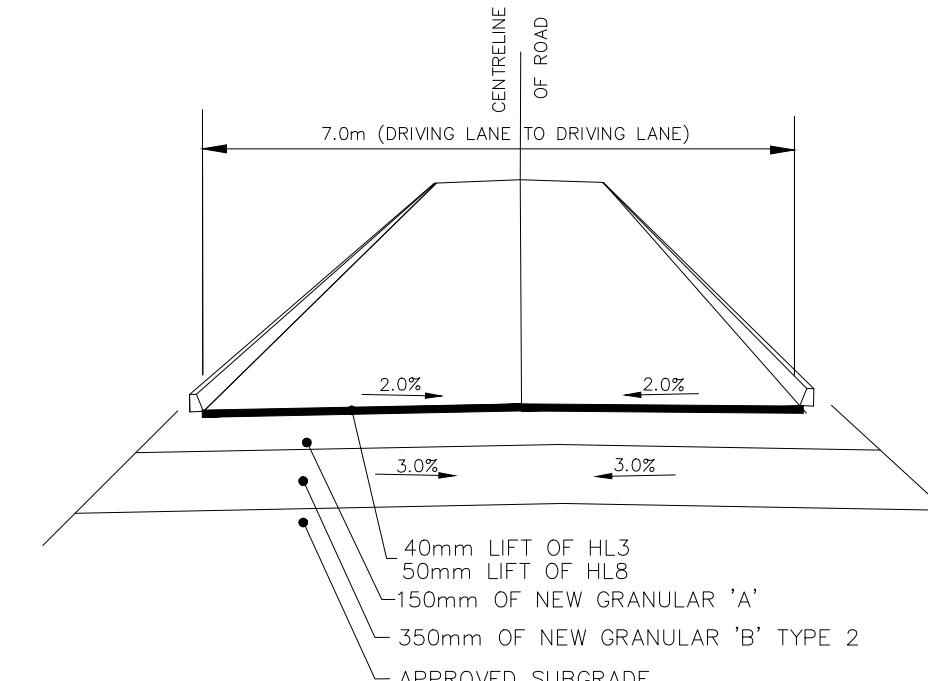

04 TYPICAL INTERIOR ROAD DETAIL SCALE: N.T.S.

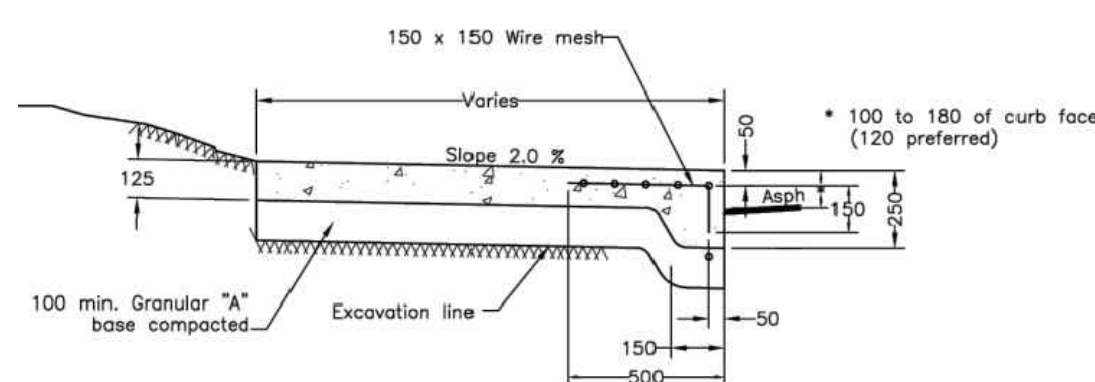

05 TYPICAL MONOLITHIC CONCRETE SIDEWALK SCALE: N.T.S.

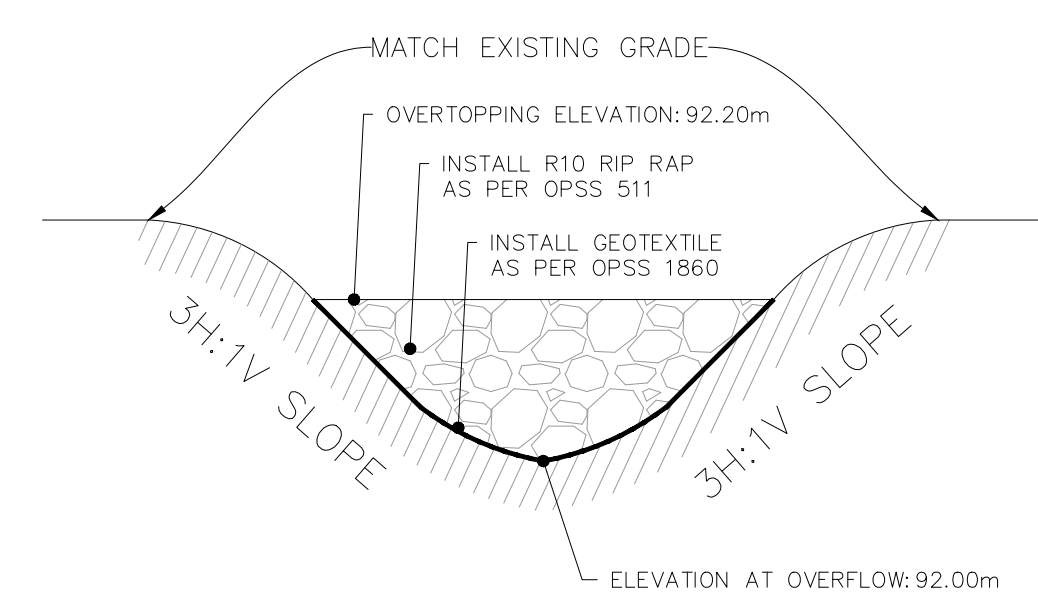

06 'TYPICAL' OVERFLOW DITCH DETAIL SCALE: N.T.S.

ONTARIO PROVINCIAL STANDARD DRAWINGS: THE FOLLOWING ONTARIO PROVINCIAL STANDARD DRAWINGS (OPSD'S) WILL BE USED. THE CONTRACTOR IS RESPONSIBLE FOR OBTAINING THE CURRENT COPIES OF THESE STANDARDS.

- 219.100 LIGHT DUTY STRAW BALE BARRIER
219.110 LIGHT-DUTY SILT FENCE BARRIER
310.010 CONCRETE SIDEWALK
400.020 CAST IRON, SQUARE FRAME WITH SQUARE FLAT GRATE FOR CATCH BASINS, HERRING BONE OPENINGS
401.010 CAST IRON, SQUARE FRAME WITH CIRCULAR CLOSED OR OPEN COVER FOR MAINTENANCE HOLES
401.020 CAST IRON, CIRCULAR FRAME WITH CIRCULAR 745MM COVER FOR MAINTENANCE HOLES
403.010 GALVANIZED STEEL HONEYCOMB GRATING FOR DITCH INLETS
600.040 CONCRETE BARRIER CURB WITH STANDARD GUTTER
604.010 90 DEGREE CONCRETE OUTLET FOR CONCRETE CURB AND GUTTER
605.010 45 DEGREE CONCRETE OUTLET FOR CONCRETE CURB AND GUTTER
701.010 PRECAST CONCRETE MAINTENANCE HOLE, 1200MM DIAMETER
701.030 PRECAST CONCRETE MAINTENANCE HOLE COMPONENTS, 1200MM DIAMETER, TAPERED TOP AND FLAT CAP
702.040 PRECAST CONCRETE DITCH INLET MAINTENANCE HOLE-TYPE A, 1200X1200 MM
705.010 PRECAST CONCRETE CATCH BASIN, 600X600 MM
703.021 PRECAST CONCRETE TWIN INLET FLAT CAP
802.010 FLEXIBLE PIPE, EMBEDMENT AND BACKFILL, EARTH EXCAVATION
803.031 FROST TREATMENT- PIPE CULVERTS, FROST PENETRATION LINE BETWEEN TOP OF PIPE AND BEDDING GRADE
804.030 CONCRETE HEADWALL FOR PIPE LESS THAN 900MM DIAMETER

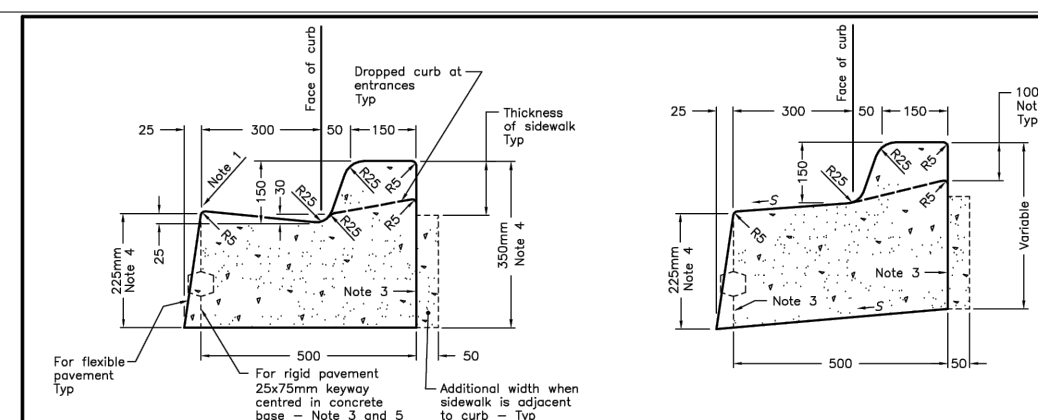

ONTARIO PROVINCIAL STANDARD DRAWING CONCRETE BARRIER CURB WITH STANDARD GUTTER OPSD 600.040

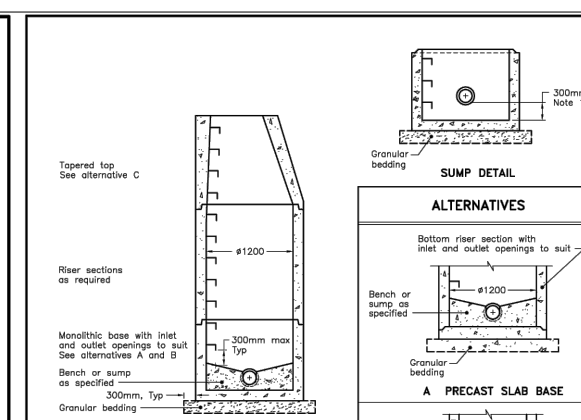

ONTARIO PROVINCIAL STANDARD DRAWING PRECAST CONCRETE MAINTENANCE HOLE 1200MM DIAMETER OPSD 701-010

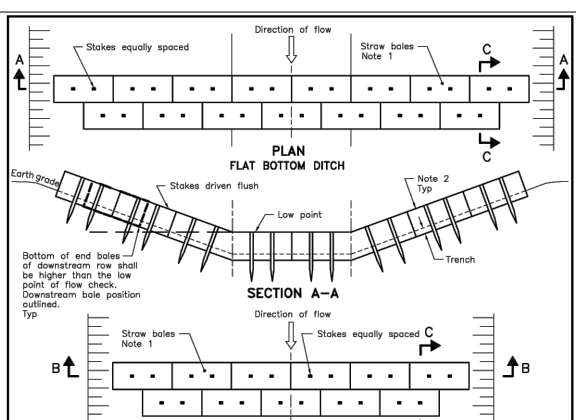

ONTARIO PROVINCIAL STANDARD DRAWING STRAW BALE FLOW CHECK DAM OPSD 219.180

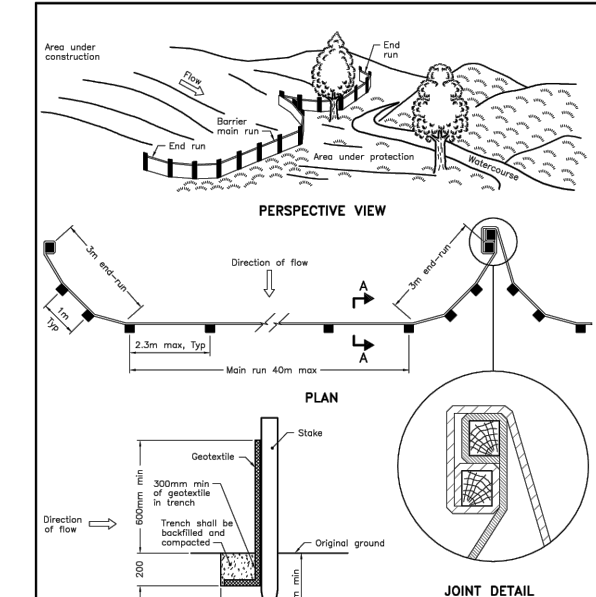

ONTARIO PROVINCIAL STANDARD DRAWING LIGHT-DUTY SILT FENCE BARRIER OPSD 219.110

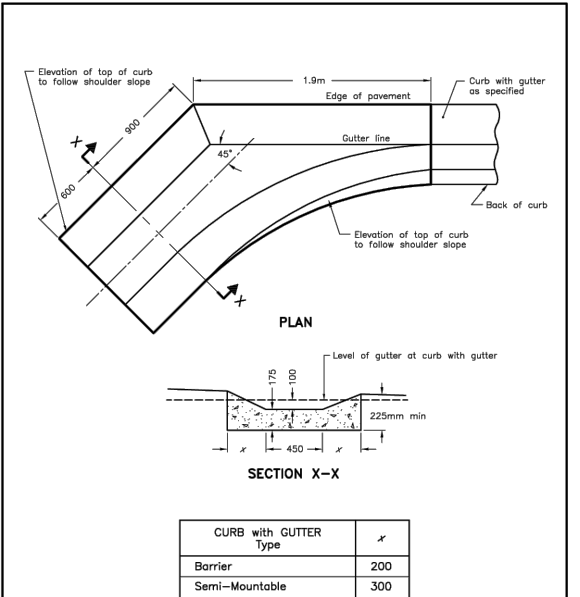

ONTARIO PROVINCIAL STANDARD DRAWING 45° CONCRETE OUTLET FOR CONCRETE CURB WITH GUTTER AT END OF RUN OPSD 605.030

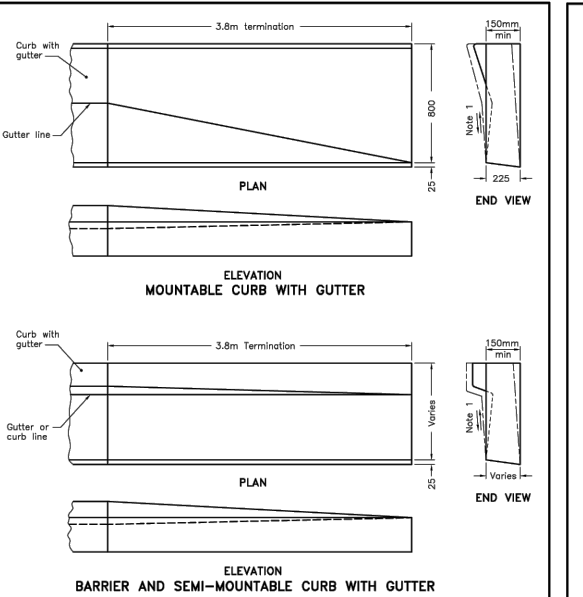

ONTARIO PROVINCIAL STANDARD DRAWING METHOD OF TERMINATION FOR CONCRETE CURB WITH GUTTER OPSD 608.010

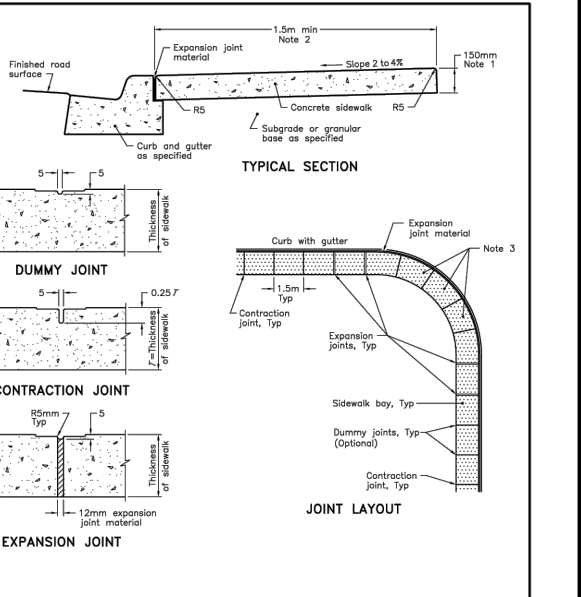

ONTARIO PROVINCIAL STANDARD DRAWING CONCRETE SIDEWALK ADJACENT TO CURB WITH GUTTER OPSD 310.020

CLIENT LOGO, KEY PLAN(S), DISCLAIMER NOTES, PROJECT INFORMATION (2026-01-16, SH, ISSUED FOR STORMWATER REPORT), PROFESSIONAL ENGINEER (K. T. HAWLEY), PROJECT (FOLKARD LANE DEVELOPMENT), DRAWING (DETAILS), SHEET # (D1), and GREER GALLOWAY logo.

Appendix B

Rainfall Intensity Data

Active coordinate

44° 1' 45" N, 77° 8' 15" W (44.029167,-77.137500)

Retrieved: Mon, 14 Nov 2022 18:04:47 GMT



Location summary

These are the locations in the selection.

IDF Curve: 44° 1' 45" N, 77° 8' 15" W (44.029167,-77.137500)

Results

An IDF curve was found.

Coordinate: 44.029167, -77.137500
IDF curve year: 2010

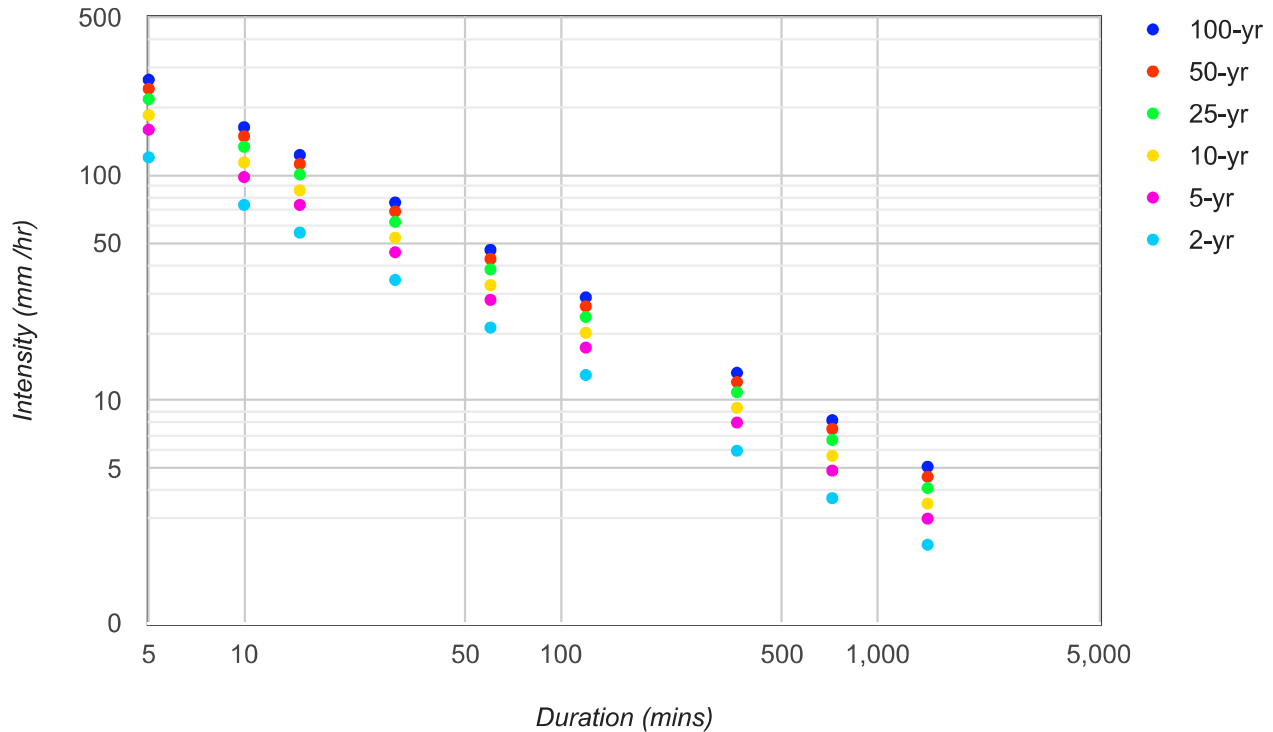

Coefficient summary

IDF Curve: 44° 1' 45" N, 77° 8' 15" W (44.029167,-77.137500)

Retrieved: Mon, 14 Nov 2022 18:04:47 GMT

Data year: 2010

IDF curve year: 2010

Return period	2-yr	5-yr	10-yr	25-yr	50-yr	100-yr
A	21.1	28.0	32.5	38.2	42.5	46.6
B	-0.699	-0.699	-0.699	-0.699	-0.699	-0.699

Statistics**Rainfall intensity (mm hr⁻¹)**

Duration	5-min	10-min	15-min	30-min	1-hr	2-hr	6-hr	12-hr	24-hr
2-yr	119.8	73.8	55.6	34.3	21.1	13.0	6.0	3.7	2.3
5-yr	159.0	98.0	73.8	45.5	28.0	17.2	8.0	4.9	3.0
10-yr	184.6	113.7	85.6	52.8	32.5	20.0	9.3	5.7	3.5
25-yr	217.0	133.7	100.7	62.0	38.2	23.5	10.9	6.7	4.1
50-yr	241.4	148.7	112.0	69.0	42.5	26.2	12.1	7.5	4.6
100-yr	264.7	163.0	122.8	75.6	46.6	28.7	13.3	8.2	5.1

Rainfall depth (mm)

Duration	5-min	10-min	15-min	30-min	1-hr	2-hr	6-hr	12-hr	24-hr
2-yr	10.0	12.3	13.9	17.1	21.1	26.0	36.2	44.6	54.9
5-yr	13.3	16.3	18.4	22.7	28.0	34.5	48.0	59.2	72.9
10-yr	15.4	19.0	21.4	26.4	32.5	40.0	55.7	68.7	84.6
25-yr	18.1	22.3	25.2	31.0	38.2	47.1	65.5	80.7	99.4
50-yr	20.1	24.8	28.0	34.5	42.5	52.4	72.9	89.8	110.6
100-yr	22.1	27.2	30.7	37.8	46.6	57.4	79.9	98.5	121.3

Terms of Use

You agree to the [Terms of Use](#) of this site by reviewing, using, or interpreting these data.

[Ontario Ministry of Transportation | Terms and Conditions | About](#)

Last Modified: September 2016

Appendix C

Hydrologic Calculations

Predevelopment Peak Flow Calculations

FOLKARD LANE GRADING

Completed by: Rob Asselstine

Reviewed by:

DATE: January 9th, 2026

Drainage Area: 3.22 ha

Hydrologic soil group B

Land Use	Area (Ha)	Runoff Coefficient	C x A	CN Value	CN x A
Gravel	0.19	0.60	0.11	85	16
Wooded/Grass	3.03	0.25	0.76	58	176
Total	3.22		0.87		192

Composite CN Value: 60

Composite Runoff Coefficient: 0.27

% Imperviousness: 6%

Watershed Length 235 m

Elevation - Top: 94.70 m

Elevation - Bottom: 92.20 m

Watershed Slope: 1.1%

Time of Concentration, $T_c =$ 41 minutes (calculated using the Airport Method for $C < 0.4$)

Watershed Time to Peak, $T_p =$ 27 minutes ($2/3$ of T_c)

Runoff Storage Coefficient, $S =$ 172

Initial Abstraction, $I_a =$ 12.931 mm

Return Period Coefficient

			A	B	
2-Year Intensity	28	mm/hr			
5-Year Intensity	37	mm/hr		21.1	-0.699
10-Year Intensity	43	mm/hr		28	-0.699
25-Year Intensity	50	mm/hr		32.5	-0.699
50-Year Intensity	56	mm/hr		38.2	-0.699
100-Year Intensity	61	mm/hr		42.5	-0.699
				46.6	-0.699
2-year Flow, Q	67	L/s			
5-Year Flow, Q	89	L/s			
10-Year Flow, Q	103	L/s			
25-Year Flow, Q	121	L/s			
50-Year Flow, Q	135	L/s			
100-Year Flow	148	L/s			

Postdevelopment Peak Flow Calculations

FOLKARD LANE GRADING

Completed by: Rob Asselstine

Reviewed by:

DATE: January 9th, 2026

Drainage Area: 3.22 ha

Hydrologic soil group B

Land Use	Area (Ha)	Runoff Coefficient	C x A	CN Value	CN x A
Grass	1.24	0.25	0.31	80	99
Concrete	0.19	0.90	0.17	0	0
Roof	0.93	0.90	0.84	98	91
Asphalt	0.86	0.90	0.77	98	84
Total	3.22		2.09		275

Composite CN Value: 85

Composite Runoff Coefficient: 0.65

% Imperviousness: 62%

Watershed Length 315 m

Elevation - Top: 95.06 m

Elevation - Bottom: 91.85 m

Watershed Slope: 1.0%

Time of Concentration, T_c = 16 minutes (calculated using the Bransby-William's for $C > 0.4$)
 Watershed Time to Peak, T_p = 11 minutes ($2/3$ of T_c)

Runoff Storage Coefficient, S = 44
 Initial Abstraction, I_a = 3.266 mm

Return Period Coefficient

		A	B
2-year Intensity	53 mm/hr		
5-Year Intensity	71 mm/hr	21.1	-0.699
10-Year Intensity	82 mm/hr	28	-0.699
25-Year Intensity	97 mm/hr	32.5	-0.699
50-Year Intensity	107 mm/hr	38.2	-0.699
100-Year Intensity	118 mm/hr	42.5	-0.699
		46.6	-0.699

2-Year Flow	310	L/s
5-Year Flow, Q	411	L/s
10-Year Flow	478	L/s
20-Year Flow	561	L/s
50-year Flow	625	L/s
100-Year Flow	685	L/s

PostDevelopment SubCatchment Peak Flows

FOLKARD LANE GRADING

Completed by: Rob Asselstine

Reviewed by:

DATE: January 9th, 2026

Catchment ID:	Asphalt	Concrete	Roofs	Grass	Total	CRC	% Impervious	WtrShed Length	WtrShed Elev.	WtrShed Slope	TC	5y Intensity	5yr Peak Flow	100y Intensity	100yr Peak Flow
A1	0.10	0.02	0.02	0.10	0.24	0.63	58.0%	137.0	1.8	1.3%	15	73.8	30.5	123	50.7
A2	0.01	0.00	0.02	0.04	0.07	0.53	43.6%	90.0	0.6	0.7%	15	73.8	7.7	123	12.8
A3	0.03	0.01	0.03	0.05	0.12	0.65	61.7%	87.0	1.0	1.1%	15	73.8	16.7	123	27.7
A4	0.03	0.01	0.05	0.06	0.17	0.65	61.5%	101.2	0.8	0.8%	15	73.8	22.0	123	36.7
A5	0.02	0.01	0.00	0.00	0.03	0.87	96.0%	54.0	0.9	1.6%	15	73.8	5.9	123	9.8
A6	0.02			0.02	0.04	0.58	50.7%	54.0	0.9	1.6%	15	73.8	4.8	123	8.0
A7	0.05	0.00	0.02	0.04	0.11	0.65	61.9%	54.2	0.8	1.5%	15	73.8	14.5	123	24.2
A8	0.05	0.00	0.05	0.01	0.10	0.86	94.0%	38.4	0.7	1.8%	15	73.8	18.4	123	30.6
A9	0.01	0.00	0.02	0.00	0.04	0.83	88.6%	38.4	0.5	1.2%	15	73.8	6.2	123	10.4
A10	0.02	0.04	0.22	0.44	0.71	0.50	38.5%	75.8	3.0	4.0%	15	73.8	72.9	123	121.2
A11	0.06	0.02	0.06	0.02	0.16	0.83	89.2%	56.8	0.5	0.9%	15	73.8	26.8	123	44.7
A12	0.01			0.01	0.01	0.57	49.4%	13.8	1.2	8.5%	15	73.8	1.5	123	2.5
A13	0.02	0.00	0.01	0.01	0.03	0.78	81.4%	24.3	0.6	2.4%	15	73.8	5.2	123	8.7
A14	0.02	0.00	0.03	0.00	0.05	0.88	96.4%	34.6	0.8	2.3%	15	73.8	8.5	123	14.1
A15	0.02	0.00	0.02	0.01	0.04	0.78	82.3%	75.0	1.1	1.4%	15	73.8	6.4	123	10.7
A16	0.02	0.00	0.01	0.01	0.05	0.76	78.5%	81.0	0.5	0.7%	15	73.8	7.5	123	12.5
A17	0.02	0.00	0.03	0.00	0.05	0.88	96.4%	29.3	0.8	2.6%	15	73.8	8.5	123	14.1
A18	0.02	0.00		0.01	0.03	0.69	67.6%	42.3	0.2	0.6%	15	73.8	4.0	123	6.6
A19	0.03	0.00	0.03	0.01	0.08	0.79	83.5%	48.5	0.8	1.6%	15	73.8	12.2	123	20.4
A20	0.02	0.00	0.03	0.00	0.04	0.89	98.2%	25.4	0.7	2.7%	15	73.8	8.2	123	13.6
A21	0.01	0.00	0.02	0.00	0.04	0.87	95.9%	21.9	0.6	2.6%	15	73.8	6.6	123	10.9
A22	0.04	0.01	0.02	0.01	0.07	0.81	86.8%	28.0	0.8	2.7%	15	73.8	12.0	123	20.0
A23	0.02	0.01	0.02	0.02	0.07	0.71	70.1%	44.0	1.8	4.0%	15	73.8	9.4	123	15.7
A24	0.05	0.01	0.02	0.03	0.11	0.72	72.4%	90.0	1.0	1.1%	15	73.8	15.9	123	26.4
A25	0.01			0.02	0.03	0.50	38.9%	30.0	1.1	3.7%	15	73.8	3.1	123	5.1
A26	0.01			0.01	0.02	0.50	37.7%	23.2	1.0	4.1%	15	73.8	2.3	123	3.8
A27	0.00			0.04	0.04	0.30	7.6%	68.5	1.8	2.7%	15.6	71.8	2.5	119	4.2
A28	0.01			0.01	0.02	0.57	48.8%	17.0	0.1	0.6%	15	73.8	2.2	123	3.7
A29	0.01			0.01	0.02	0.56	48.2%	16.4	0.9	5.7%	15	73.8	1.9	123	3.2
A30	0.02			0.02	0.04	0.58	50.5%	34.0	0.8	2.4%	15	73.8	4.8	123	8.0
A31	0.11	0.03	0.20	0.24	0.58	0.64	59.6%	268.7	2.1	0.8%	17	67.6	69.8	113	116.2
Total	0.86	0.19	0.93	1.24	3.22	0.65	61.5%	314.8	3.2	1.0%	15.91	70.8	411.5	118	684.9

Storm Sewer Design Sheet (5-Year Design Flow)

FOLKARD LANE GRADING

Completed by: Rob Asselstine

Reviewed by:

DATE: January 8, 2026

http://www.mto.gov.on.ca/IDF/Curves/map_acquisition.shtml

Location				intensity	28.0	5-Year					Sewer Information								Watershed Information					
Pipe Network Groups	Contributing Sub Areas	From	To	Areas (ha)	C value	AC	Σ AC	Tc (min)	Intensity (mm/hr)	Peak Flow (L/s)	Type of Pipe	Nominal Pipe Size (mm)	Actual Pipe Size (m)	Slope (%)	Length (m)	Capacity (L/s)	Velocity (m/s)	Capacity (Qp/Qf)	Time of Flow (min)	E: Top	E: Bottom	Length	Slope	TC min
Group 1	A3	CB 1	CB 2	0.125	0.650	0.081	0.081	15.00	73.79	16.63	HDPE	300	0.305	0.50%	8.083	71.27	0.98	0.23	0.14	94.55	94.03	176.00	0.30%	32.61
	A4, A3	CB 2	CBMH 1	0.165	0.650	0.108	0.189	15.14	73.32	38.43	HDPE	300	0.305	0.30%	25.811	55.21	0.76	0.70	0.57	94.50	93.58	140.00	0.66%	22.11
	A8	CB 3	CBMH 1	0.104	0.860	0.090	0.090	15.00	73.79	18.38	HDPE	300	0.305	0.30%	8.311	55.21	0.76	0.33	0.18	94.09	93.42	154.00	0.44%	26.41
	A9, A8, A3, A3	CBMH 1	CBMH 2	0.037	0.830	0.031	0.309	15.71	71.45	61.33	HDPE	375	0.381	0.30%	24.326	100.11	0.88	0.61	0.46	93.61	93.04	107.42	0.53%	17.70
Group 2	A13	CB 7	CB 6	0.033	0.780	0.026	0.026	15.00	73.79	5.25	HDPE	300	0.305	0.30%	12.828	55.21	0.76	0.10	0.28	93.61	93.04	107.42	0.53%	17.70
	A7, A13	CB 6	CB 4	0.109	0.650	0.071	0.096	15.28	72.83	19.47	HDPE	300	0.305	1.12%	31.21	106.67	1.46	0.18	0.36	94.04	92.88	90.00	1.29%	12.42
	A17	CB 5	CB 4	0.047	0.880	0.042	0.042	15.00	73.79	8.52	HDPE	300	0.305	0.30%	10.861	55.21	0.76	0.15	0.24	93.02	92.27	71.00	1.06%	10.20
	A14, A17, A7, A13	CB 4	CBMH 2	0.047	0.880	0.042	0.179	15.64	71.67	35.71	HDPE	300	0.305	0.30%	9.491	55.21	0.76	0.65	0.21	93.02	92.19	85.00	0.98%	12.40
Group 3	A16	CB 11	CB 9	0.048	0.760	0.036	0.036	15.00	73.79	7.48	HDPE	300	0.305	1.67%	20.351	130.26	1.79	0.06	0.19	93.14	92.24	79.00	1.14%	11.17
	A21	CB 10	CB 9	0.037	0.870	0.032	0.032	15.00	73.79	6.53	HDPE	300	0.305	0.30%	7.612	55.21	0.76	0.12	0.17	93.50	92.50	65.00	1.54%	8.66
	(A18 & A20), A16, A21	CB 9	CB 8	0.065	0.790	0.051	0.119	15.19	73.14	24.29	HDPE	300	0.305	0.30%	11.413	55.21	0.76	0.44	0.25	93.20	91.80	85.00	1.65%	11.17
	A19, A18, A20, A16, A21	CB 8	CBMH 2	0.075	0.790	0.059	0.179	15.44	72.31	35.97	HDPE	300	0.305	0.30%	44.51	55.21	0.76	0.65	0.98	94.10	93.40	48.00	1.46%	6.46
Group 4	A15, Group 1, 2, 3	CBMH 2	DIMH 1	0.040	0.780	0.031	0.698	15.69	71.50	138.75	HDPE	450	0.457	0.30%	33.931	162.79	0.99	0.85	0.57	93.32	92.67	53.00	1.23%	7.39
	A10, A15, Grp 1-3	DIMH 1	CBMH 12	0.710	0.500	0.355	1.053	16.26	69.74	204.16	HDPE	450	0.457	0.80%	38.441	265.84	1.62	0.77	0.40	94.38	91.71	300.00	0.89%	44.58
Group 5	A5	CB 15	CBMH 12	0.033	0.870	0.029	0.029	15.00	73.79	5.89	HDPE	300	0.305	2.00%	52.188	142.55	1.95	0.04	0.45	92.80	91.54	197.00	0.64%	31.28
	A11, Grp 1-4	CBMH 12	CBMH13	0.158	0.830	0.131	1.213	16.66	68.57	231.16	HDPE	525	0.533	0.50%	8.845	317.04	1.42	0.73	0.10	92.80	91.54	197.00	0.64%	31.28
Group 6	A1	DITCH	CVT 1	0.237	0.630	0.149	0.149	15.00	73.79	30.61	HDPE	300	0.305	1.00%	5	100.80	1.38	0.30	0.06	92.80	91.54	197.00	0.64%	31.28
	A2, A1	DITCH	CVT 2	0.070	0.530	0.037	0.187	15.06	73.58	38.16	HDPE	300	0.305	1.00%	15	100.80	1.38	0.38	0.18	92.80	91.54	197.00	0.64%	31.28
	A6, A1, A2	DITCH	CVT3	0.040	0.580	0.023	0.210	15.24	72.97	42.60	HDPE	300	0.305	1.00%	4	100.80	1.38	0.42	0.05	92.80	91.54	197.00	0.64%	31.28
	A12, A1, A2, A6	DITCH	CVT4	0.013	0.570	0.007	0.217	15.29	72.81	44.00	HDPE	300	0.305	1.00%	3	100.80	1.38	0.44	0.04	92.80	91.54	197.00	0.64%	31.28
	A25, A1, A2, A6, A12	DITCH	CVT 5	0.030	0.500	0.015	0.232	15.33	72.69	46.92	HDPE	300	0.305	1.00%	4	100.80	1.38	0.47	0.05	92.80	91.54	197.00	0.64%	31.28
Group 7	A26, Group 1-6	CBMH13	CBMH 14	0.023	0.500	0.011	0.243	15.37	72.53	49.08	HDPE	375	0.381	0.30%	7.296	100.11	0.88	0.49	0.14	92.80	91.54	197.00	0.64%	31.28
	(A23 & A24)	CB 13	CB 14	0.173	0.715	0.123	0.123	15.00	73.79	25.30	HDPE	300	0.305	0.30%	7.574	55.21	0.76	0.46	0.17	92.80	91.54	197.00	0.64%	31.28
Group 8	A22, A23, A24	CB 14	CB 15	0.072	0.810	0.058	0.182	15.17	73.22	36.96	HDPE	300	0.305	1.68%	11.284	130.65	1.79	0.28	0.11	92.80	91.54	197.00	0.64%	31.28
	A31, A22-24	CB15	CVT 9	0.583	0.640	0.373	0.555	15.27	72.87	112.34	HDPE	450	0.457	0.50%	6	210.17	1.28	0.53	0.08	92.80	91.54	197.00	0.64%	31.28
	A30, Grp 8		CVT 8	0.040	0.580	0.023	0.578	15.35	72.61	116.68	HDPE	375	0.381	1.00%	7	182.77	1.60	0.64	0.07	92.80	91.54	197.00	0.64%	31.28
Group 9	A29, A30, Grp8		CVT 7	0.016	0.560	0.009	0.587	15.42	72.37	118.15	HDPE	450	0.457	0.98%	4.5	294.23	1.79	0.40	0.04	92.80	91.54	197.00	0.64%	31.28
	A28, A29, A30, Grp8		CVT 6	0.019	0.570	0.011	0.598	15.46	72.23	120.13	HDPE	450	0.457	1.00%	5	297.22	1.81	0.40	0.05	92.80	91.54	197.00	0.64%	31.28
	A27, Group 1-9	CBMH 14	FINAL OUTLET	0.042	0.300	0.013	2.067	15.51	72.08	414.17	HDPE	750	0.762	0.53%	41.5	845.05	1.85	0.49	0.37	92.80	91.54	197.00	0.64%	31.28

Notes:

C Values are calculated based on the Design Guidelines for Sewage Works 2008 - Ministry of Environment, Ontario

Storm Sewer Design Sheet (100-Year Design Flow)

FOLKARD LANE GRADING

Completed by: Rob Asselstine

Reviewed by:

DATE: January 8, 2026

http://www.mto.gov.on.ca/IDF/Curves/map_acquisition.shtml

Location				intensity	46.6	100-Year					Sewer Information									Watershed Information				
Pipe Network Groups	Contributing Sub Areas	From	To	Areas (ha)	C value	AC	Σ AC	Tc (min)	Intensity (mm/hr)	Peak Flow (L/s)	Type of Pipe	Nominal Pipe Size (mm)	Actual Pipe Size (m)	Slope (%)	Length (m)	Capacity (L/s)	Velocity (m/s)	Capacity (Qp/Qf)	Time of Flow (min)	E: Top	E: Bottom	Length	Slope	TC min
Group 1	A3	CB 1	CB 2	0.125	0.650	0.081	0.081	15.00	122.81	27.67	HDPE	300	0.305	0.50%	8.083	71.27	0.98	0.39	0.14	94.55	94.03	176.00	0.30%	32.61
	A4, A3	CB 2	CBMH 1	0.165	0.650	0.108	0.189	15.14	122.02	63.97	HDPE	375	0.381	0.30%	25.811	100.11	0.88	0.64	0.49	94.50	93.58	140.00	0.66%	22.11
	A8	CB 3	CBMH 1	0.104	0.860	0.090	0.090	15.00	122.81	30.59	HDPE	300	0.305	0.30%	8.311	55.21	0.76	0.55	0.18	94.09	93.42	154.00	0.44%	26.41
	A9, A8, A3, A3	CBMH 1	CBMH 2	0.037	0.830	0.031	0.309	15.63	119.34	102.42	HDPE	450	0.457	0.30%	24.326	162.79	0.99	0.63	0.41	93.61	93.04	107.42	0.53%	17.70
Group 2	A13	CB 7	CB 6	0.033	0.780	0.026	0.026	15.00	122.81	8.73	HDPE	300	0.305	0.30%	12.828	55.21	0.76	0.16	0.28	93.61	93.04	107.42	0.53%	17.70
	A7, A13	CB 6	CB 4	0.109	0.650	0.071	0.096	15.28	121.22	32.41	HDPE	300	0.305	1.12%	31.21	106.67	1.46	0.30	0.36	94.04	92.88	90.00	1.29%	12.42
	A17	CB 5	CB 4	0.047	0.880	0.042	0.042	15.00	122.81	14.18	HDPE	300	0.305	0.30%	10.861	55.21	0.76	0.26	0.24	93.02	92.27	71.00	1.06%	10.20
	A14, A17, A7, A13	CB 4	CBMH 2	0.047	0.880	0.042	0.179	15.64	119.28	59.44	HDPE	375	0.381	0.30%	9.491	100.11	0.88	0.59	0.18	93.02	92.19	85.00	0.98%	12.40
Group 3	A16	CB 11	CB 9	0.048	0.760	0.036	0.036	15.00	122.81	12.45	HDPE	300	0.305	1.67%	20.351	130.26	1.79	0.10	0.19	93.14	92.24	79.00	1.14%	11.17
	A21	CB 10	CB 9	0.037	0.870	0.032	0.032	15.00	122.81	10.87	HDPE	300	0.305	0.30%	7.612	55.21	0.76	0.20	0.17	93.50	92.50	65.00	1.54%	8.66
	(A18 & A20), A16, A21	CB 9	CB 8	0.065	0.790	0.051	0.119	15.19	121.73	40.42	HDPE	300	0.305	0.30%	11.413	55.21	0.76	0.73	0.25	93.20	91.80	85.00	1.65%	11.17
	A19, A18, A20, A16, A21	CB 8	CBMH 2	0.075	0.790	0.059	0.179	15.44	120.34	59.86	HDPE	375	0.381	0.30%	44.51	100.11	0.88	0.60	0.84	94.10	93.40	48.00	1.46%	6.46
Group 4	A15, Group 1, 2, 3	CBMH 2	DIMH 1	0.040	0.780	0.031	0.698	15.69	118.99	230.93	HDPE	600	0.610	0.30%	33.931	350.63	1.20	0.66	0.47	93.32	92.67	53.00	1.23%	7.39
	A10, A15, Grp 1-3	DIMH 1	CBMH 12	0.710	0.500	0.355	1.053	16.16	116.56	341.24	HDPE	525	0.533	0.80%	38.441	401.02	1.79	0.85	0.36	94.38	91.71	300.00	0.89%	44.58
Group 5	A5	CB 15	CBMH 12	0.033	0.870	0.029	0.029	15.00	122.81	9.80	HDPE	300	0.305	2.00%	52.188	142.55	1.95	0.07	0.45	92.80	91.54	197.00	0.64%	31.28
	A11, Grp 1-4	CBMH 12	CBMH13	0.158	0.830	0.131	1.213	16.52	114.79	386.97	HDPE	600	0.610	0.50%	8.845	452.66	1.55	0.85	0.10	92.80	91.54	197.00	0.64%	31.28
Group 6	A1	DITCH	CVT 1	0.237	0.630	0.149	0.149	15.00	122.81	50.94	HDPE	300	0.305	1.00%	5	100.80	1.38	0.51	0.06	92.80	91.54	197.00	0.64%	31.28
	A2, A1	DITCH	CVT 2	0.070	0.530	0.037	0.187	15.06	122.46	63.51	HDPE	300	0.305	1.00%	15	100.80	1.38	0.63	0.18	92.80	91.54	197.00	0.64%	31.28
	A6, A1, A2	DITCH	CVT3	0.040	0.580	0.023	0.210	15.24	121.45	70.89	HDPE	300	0.305	1.00%	4	100.80	1.38	0.70	0.05	92.80	91.54	197.00	0.64%	31.28
	A12, A1, A2, A6	DITCH	CVT4	0.013	0.570	0.007	0.217	15.29	121.18	73.23	HDPE	300	0.305	1.00%	3	100.80	1.38	0.73	0.04	92.80	91.54	197.00	0.64%	31.28
	A25, A1, A2, A6, A12	DITCH	CVT 5	0.030	0.500	0.015	0.232	15.33	120.98	78.09	HDPE	300	0.305	1.00%	4	100.80	1.38	0.77	0.05	92.80	91.54	197.00	0.64%	31.28
Group 7	A26, Group 1-6	CBMH13	CBMH 14	0.023	0.500	0.011	0.243	15.37	120.71	81.69	HDPE	375	0.381	0.30%	7.296	100.11	0.88	0.82	0.14	92.80	91.54	197.00	0.64%	31.28
	(A23 & A24)	CB 13	CB 14	0.173	0.715	0.123	0.123	15.00	122.81	42.11	HDPE	300	0.305	0.30%	7.574	55.21	0.76	0.76	0.17	92.80	91.54	197.00	0.64%	31.28
Group 8	A22, A23, A24	CB 14	CB 15	0.072	0.810	0.058	0.182	15.17	121.86	61.51	HDPE	300	0.305	1.68%	11.284	130.65	1.79	0.47	0.11	92.80	91.54	197.00	0.64%	31.28
	A31, A22-24	CB15	CVT 9	0.583	0.640	0.373	0.555	15.27	121.28	186.97	HDPE	450	0.457	0.50%	6	210.17	1.28	0.89	0.08	92.80	91.54	197.00	0.64%	31.28
	A30, Grp 8	CVT 8	CVT 8	0.040	0.580	0.023	0.578	15.35	120.84	194.19	HDPE	525	0.533	1.00%	7	448.36	2.01	0.43	0.06	92.80	91.54	197.00	0.64%	31.28
Group 9	A29, A30, Grp8	CVT 7	CVT 7	0.016	0.560	0.009	0.587	15.41	120.52	196.76	HDPE	450	0.457	0.98%	4.5	294.23	1.79	0.67	0.04	92.80	91.54	197.00	0.64%	31.28
	A28, A29, A30, Grp8	CVT 6	CVT 6	0.019	0.570	0.011	0.598	15.45	120.30	200.06	HDPE	450	0.457	1.00%	5	297.22	1.81	0.67	0.05	92.80	91.54	197.00	0.64%	31.28
	A27, Group 1-9	CBMH 14	FINAL OUTLET	0.042	0.300	0.013	2.067	15.50	120.05	689.75	HDPE	750	0.762	0.53%	41.5	845.05	1.85	0.82	0.37	92.80	91.54	197.00	0.64%	31.28

Notes:

C Values are calculated based on the Design Guidelines for Sewage Works 2008 - Ministry of Environment, Ontario

Swale Runoff Review (100 Year Design Flow)

FOLKARD LANE GRADING

Completed by: Rob Asselstine

Reviewed by:

DATE: January 9th, 2026

http://www.mto.gov.on.ca/IDF_Curves/map_acquisition.shtml

Location	Intensity 46.6	100 year				
Area Description	Areas (ha)	C value	Σ AC	Tc (min)	Intensity (mm/hr)	Peak Flow (L/s)
Swale #1	0.413	0.590	0.243	15.37	120.71	81.69
Swale #2	0.903	0.662	0.598	15.45	120.30	200.06
Outlet	3.190	0.648	2.067	15.50	120.05	689.75

Folkard Lane Multi-Residential Development

Project Number: 25-5035A

Swale Capacity Calculations

Capacity of Swale #1

Minimum Side Slope: 3:1

Minimum Longitudinal Slope: 0.50%

Manning's Roughness Coefficient = 0.030

Ditch Side Slope Width @ 3:1 = 5.4 m

Ditch Depth = **0.900** m

Ditch 'Flat Bottom' Width = **0.000** m (bottom rounding)

Flow Area = 2.430 m²

Wetted Perimeter = 5.69 m

Hydraulic Radius = 0.427 m

Channel Slope = **0.006** m/m

Velocity = 1.464 m/s

Q=VA= 3557.267 L/s

% Full = 2.3%

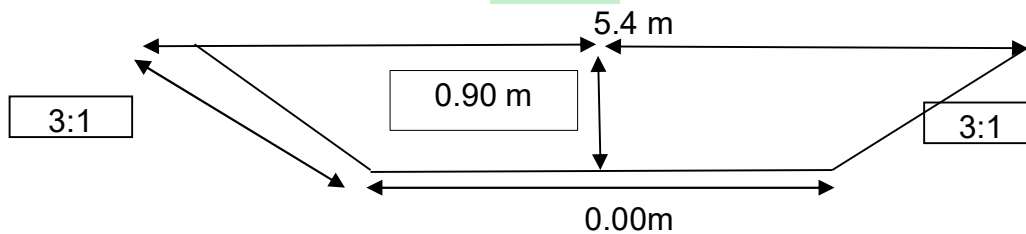

Swale Capacity Calculations

Capacity of Swale #2

Minimum Side Slope: 3:1
Minimum Longitudinal Slope: 0.50%

Manning's Roughness Coefficient = 0.030
Ditch Side Slope Width @ 3:1 = 4.8 m
Ditch Depth = 0.80 m
Ditch 'Flat Bottom' Width = 0.000 m (bottom rounding)
Flow Area = 1.920 m²
Wetted Perimeter = 5.06 m
Hydraulic Radius = 0.379 m
Channel Slope = 0.006 m/m
Velocity = 1.353 m/s

Q=VA= 2598.422 L/s
% Full = 7.7%

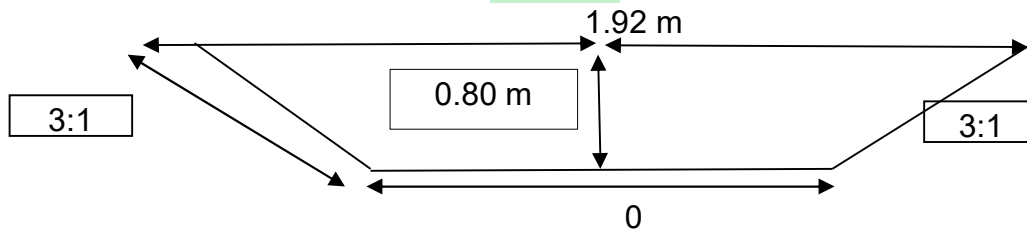

Swale Capacity Calculations

Capacity of Outlet Swale

Minimum Side Slope: 3:1
Minimum Longitudinal Slope: 2.00%

Manning's Roughness Coefficient = 0.030
Ditch Side Slope Width @ 3:1 = 1.8 m
Ditch Depth = **0.300** m
Ditch 'Flat Bottom' Width = **0.000** m (bottom rounding)
Flow Area = 0.270 m²
Wetted Perimeter = 1.90 m
Hydraulic Radius = 0.142 m
Channel Slope = **0.025** m/m
Velocity = 1.437 m/s
Q=VA= 387.871 L/s

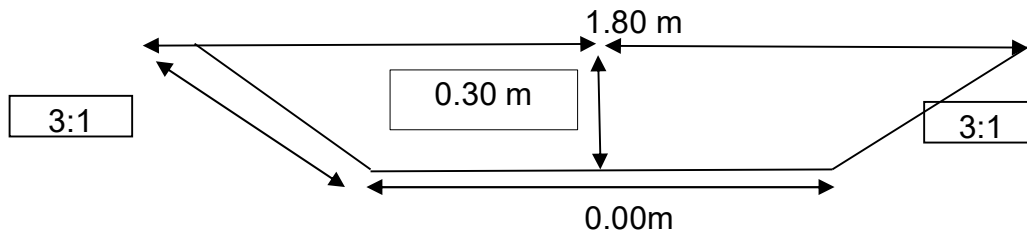

Appendix D

Oil Grit Separator

Imbrium® Systems

ESTIMATED NET ANNUAL SEDIMENT (TSS) LOAD REDUCTION

01/08/2026

Province:	Ontario
City:	Picton
Nearest Rainfall Station:	BELLEVILLE
Climate Station Id:	6150689
Years of Rainfall Data:	29

Project Name:	Folkard Lane Development
Project Number:	25-5035A
Designer Name:	Hashir Khan
Designer Company:	Greer Galloway - Division of JP2G
Designer Email:	hashir.khan@jp2g.com
Designer Phone:	519-589-9500
EOR Name:	
EOR Company:	
EOR Email:	
EOR Phone:	

Site Name:	Folkard Lane Development
------------	--------------------------

Drainage Area (ha):	3.22
% Imperviousness:	62.00

Runoff Coefficient 'c': 0.67

Particle Size Distribution:	Fine
-----------------------------	------

Target TSS Removal (%):	80.0
-------------------------	------

Required Water Quality Runoff Volume Capture (%):	90.00
Estimated Water Quality Flow Rate (L/s):	74.37
Oil / Fuel Spill Risk Site?	Yes
Upstream Flow Control?	No
Peak Conveyance (maximum) Flow Rate (L/s):	685.00
Influent TSS Concentration (mg/L):	100
Estimated Average Annual Sediment Load (kg/yr):	1124
Estimated Average Annual Sediment Volume (L/yr):	913

Net Annual Sediment (TSS) Load Reduction Sizing Summary	
Stormceptor Model	TSS Removal Provided (%)
EFO4	56
EFO5	64
EFO6	72
EFO8	81
EFO10	87
EFO12	91

Recommended Stormceptor EFO Model: EFO8

Estimated Net Annual Sediment (TSS) Load Reduction (%): 81

Water Quality Runoff Volume Capture (%): > 90



THIRD-PARTY TESTING AND VERIFICATION

► Stormceptor® EF and Stormceptor® EFO are the latest evolutions in the Stormceptor® oil-grit separator (OGS) technology series, and are designed to remove a wide variety of pollutants from stormwater and snowmelt runoff. These technologies have been third-party tested in accordance with the Canadian ETV **Procedure for Laboratory Testing of Oil-Grit Separators** and performance has been third-party verified in accordance with the **ISO 14034 Environmental Technology Verification (ETV)** protocol.

PERFORMANCE

► Stormceptor® EF and EFO remove stormwater pollutants through gravity separation and floatation, and feature a patent-pending design that generates positive removal of total suspended solids (TSS) throughout each storm event, including high-intensity storms. Captured pollutants include sediment, free oils, and sediment-bound pollutants such as nutrients, heavy metals, and petroleum hydrocarbons. Stormceptor is sized to remove a high level of TSS from the frequent rainfall events that contribute the vast majority of annual runoff volume and pollutant load. The technology incorporates an internal bypass to convey excessive stormwater flows from high-intensity storms through the device without resuspension and washout (scour) of previously captured pollutants. Proper routine maintenance ensures high pollutant removal performance and protection of downstream waterways.

PARTICLE SIZE DISTRIBUTION (PSD)

► The Canadian ETV PSD shown in the table below was used, or in part, for this sizing. This is the identical PSD that is referenced in the Canadian ETV **Procedure for Laboratory Testing of Oil-Grit Separators** for both sediment removal testing and scour testing. The Canadian ETV PSD contains a wide range of particle sizes in the sand and silt fractions, and is considered reasonably representative of the particle size fractions found in typical urban stormwater runoff.

Particle Size (µm)	Percent Less Than	Particle Size Fraction (µm)	Percent
1000	100	500-1000	5
500	95	250-500	5
250	90	150-250	15
150	75	100-150	15
100	60	75-100	10
75	50	50-75	5
50	45	20-50	10
20	35	8-20	15
8	20	5-8	10
5	10	2-5	5
2	5	<2	5

Rainfall Intensity (mm / hr)	Percent Rainfall Volume (%)	Cumulative Rainfall Volume (%)	Flow Rate (L/s)	Flow Rate (L/min)	Surface Loading Rate (L/min/m ²)	Removal Efficiency (%)	Incremental Removal (%)	Cumulative Removal (%)
0.50	8.1	8.1	3.01	180.0	38.0	100	8.1	8.1
1.00	20.0	28.0	6.02	361.0	77.0	100	20.0	28.0
2.00	16.5	44.5	12.03	722.0	154.0	89	14.8	42.8
3.00	11.6	56.2	18.05	1083.0	230.0	82	9.5	52.3
4.00	8.3	64.5	24.06	1444.0	307.0	78	6.5	58.8
5.00	6.1	70.6	30.08	1805.0	384.0	75	4.5	63.4
6.00	5.1	75.7	36.09	2166.0	461.0	71	3.6	67.0
7.00	3.9	79.6	42.11	2526.0	538.0	68	2.6	69.6
8.00	2.8	82.3	48.12	2887.0	614.0	65	1.8	71.4
9.00	2.0	84.3	54.14	3248.0	691.0	64	1.3	72.7
10.00	2.2	86.6	60.15	3609.0	768.0	63	1.4	74.1
11.00	1.9	88.5	66.17	3970.0	845.0	63	1.2	75.3
12.00	1.1	89.6	72.19	4331.0	922.0	62	0.7	76.0
13.00	1.1	90.7	78.20	4692.0	998.0	62	0.7	76.7
14.00	1.1	91.8	84.22	5053.0	1075.0	60	0.7	77.4
15.00	1.0	92.8	90.23	5414.0	1152.0	58	0.6	77.9
16.00	0.7	93.5	96.25	5775.0	1229.0	56	0.4	78.3
17.00	1.2	94.7	102.26	6136.0	1305.0	55	0.7	79.0
18.00	0.5	95.2	108.28	6497.0	1382.0	53	0.3	79.3
19.00	0.6	95.8	114.29	6858.0	1459.0	50	0.3	79.5
20.00	0.4	96.2	120.31	7219.0	1536.0	48	0.2	79.8
21.00	0.0	96.2	126.32	7579.0	1613.0	45	0.0	79.8
22.00	0.5	96.7	132.34	7940.0	1689.0	43	0.2	80.0
23.00	0.3	97.0	138.36	8301.0	1766.0	42	0.1	80.1
24.00	0.2	97.2	144.37	8662.0	1843.0	40	0.1	80.2
25.00	0.7	97.9	150.39	9023.0	1920.0	38	0.3	80.4
30.00	1.8	99.7	180.46	10828.0	2304.0	32	0.6	81.0
35.00	0.0	99.7	210.54	12632.0	2688.0	28	0.0	81.0
40.00	0.3	100.0	240.62	14437.0	3072.0	24	0.1	81.1
45.00	0.0	100.0	270.70	16242.0	3456.0	22	0.0	81.1
Estimated Net Annual Sediment (TSS) Load Reduction =								81 %

Climate Station ID: 6150689 Years of Rainfall Data: 29



RAINFALL DATA FROM BELLEVILLE RAINFALL STATION

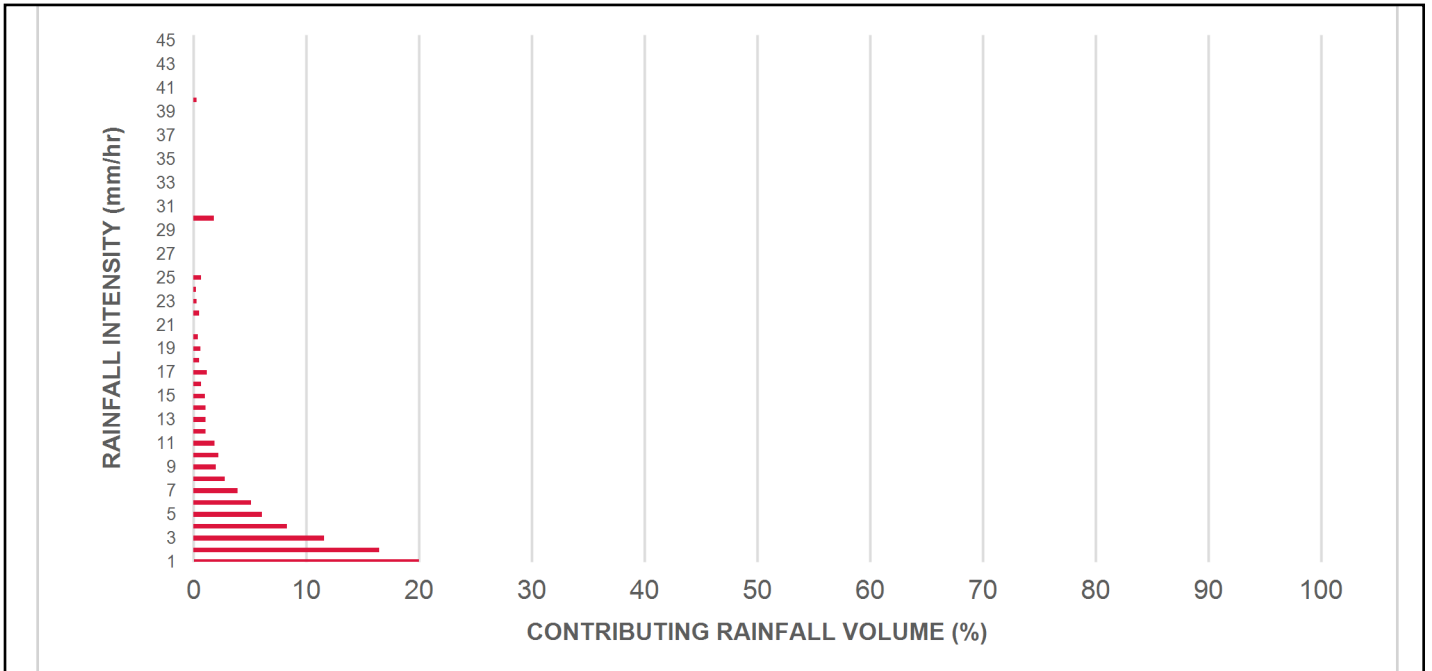

INCREMENTAL AND CUMULATIVE TSS REMOVAL FOR THE RECOMMENDED STORMCEPTOR® MODEL

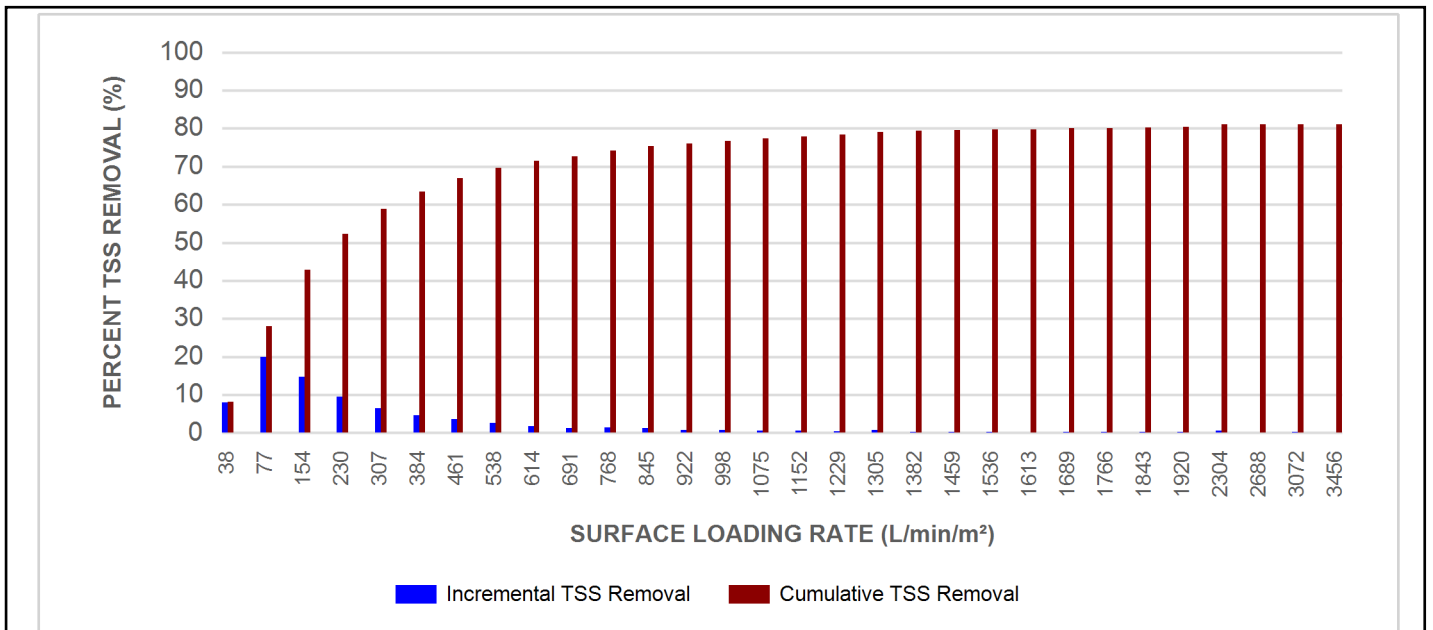

Maximum Pipe Diameter / Peak Conveyance

Stormceptor EF / EFO	Model Diameter		Min Angle Inlet / Outlet Pipes	Max Inlet Pipe Diameter		Max Outlet Pipe Diameter		Peak Conveyance Flow Rate	
	(m)	(ft)		(mm)	(in)	(mm)	(in)	(L/s)	(cfs)
EF4 / EFO4	1.2	4	90	609	24	609	24	425	15
EF5 / EFO5	1.5	5	90	762	30	762	30	710	25
EF6 / EFO6	1.8	6	90	914	36	914	36	990	35
EF8 / EFO8	2.4	8	90	1219	48	1219	48	1700	60
EF10 / EFO10	3.0	10	90	1828	72	1828	72	2830	100
EF12 / EFO12	3.6	12	90	1828	72	1828	72	2830	100

SCOUR PREVENTION AND ONLINE CONFIGURATION

► Stormceptor® EF and EFO feature an internal bypass and superior scour prevention technology that have been demonstrated in third-party testing according to the scour testing provisions of the Canadian ETV Procedure for Laboratory Testing of Oil-Grit Separators, and the exceptional scour test performance has been third-party verified in accordance with the ISO 14034 ETV protocol. As a result, Stormceptor EF and EFO are approved for online installation, eliminating the need for costly additional bypass structures, piping, and installation expense.

DESIGN FLEXIBILITY

► Stormceptor® EF and EFO offers design flexibility in one simplified platform, accepting stormwater flow from a single inlet pipe or multiple inlet pipes, and/or surface runoff through an inlet grate. The device can also serve as a junction structure, accommodate a 90-degree inlet-to-outlet bend angle, and can be modified to ensure performance in submerged conditions.

OIL CAPTURE AND RETENTION

► While Stormceptor® EF will capture and retain oil from dry weather spills and low intensity runoff, Stormceptor® EFO has demonstrated superior oil capture and greater than 99% oil retention in third-party testing according to the light liquid re-entrainment testing provisions of the Canadian ETV Procedure for Laboratory Testing of Oil-Grit Separators. Stormceptor EFO is recommended for sites where oil capture and retention is a requirement.

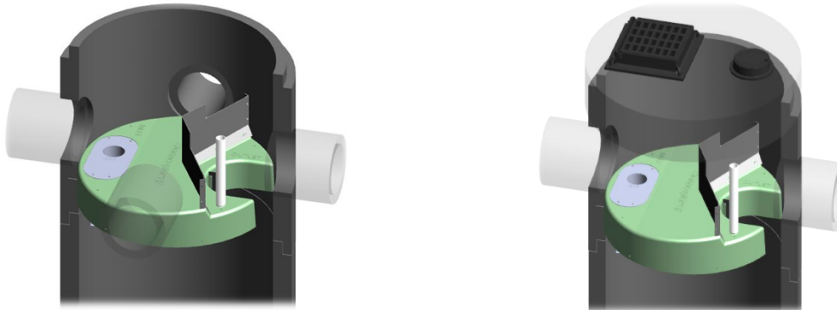

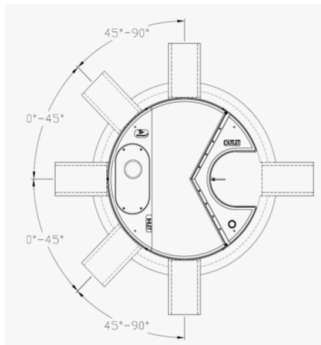

INLET-TO-OUTLET DROP

Elevation differential between inlet and outlet pipe inverts is dictated by the angle at which the inlet pipe(s) enters the unit.

0° - 45° : The inlet pipe is 1-inch (25mm) higher than the outlet pipe.

45° - 90° : The inlet pipe is 2-inches (50mm) higher than the outlet pipe.

HEAD LOSS

The head loss through Stormceptor EF is similar to that of a 60-degree bend structure. The applicable K value for calculating minor losses through the unit is 1.1. For submerged conditions the applicable K value is 3.0.

Pollutant Capacity

Stormceptor EF / EFO	Model Diameter		Depth (Outlet Pipe Invert to Sump Floor)		Oil Volume		Recommended Sediment Maintenance Depth *		Maximum Sediment Volume *		Maximum Sediment Mass **	
	(m)	(ft)	(m)	(ft)	(L)	(Gal)	(mm)	(in)	(L)	(ft³)	(kg)	(lb)
EF4 / EFO4	1.2	4	1.52	5.0	265	70	203	8	1190	42	1904	5250
EF5 / EFO5	1.5	5	1.62	5.3	420	111	305	10	2124	75	2612	5758
EF6 / EFO6	1.8	6	1.93	6.3	610	160	305	12	3470	123	5552	15375
EF8 / EFO8	2.4	8	2.59	8.5	1070	280	610	24	8780	310	14048	38750
EF10 / EFO10	3.0	10	3.25	10.7	1670	440	610	24	17790	628	28464	78500
EF12 / EFO12	3.6	12	3.89	12.8	2475	655	610	24	31220	1103	49952	137875

*Increased sump depth may be added to increase sediment storage capacity

** Average density of wet packed sediment in sump = 1.6 kg/L (100 lb/ft³)

Feature	Benefit	Feature Appeals To
Patent-pending enhanced flow treatment and scour prevention technology	Superior, verified third-party performance	Regulator, Specifying & Design Engineer
Third-party verified light liquid capture and retention for EFO version	Proven performance for fuel/oil hotspot locations	Regulator, Specifying & Design Engineer, Site Owner
Functions as bend, junction or inlet structure	Design flexibility	Specifying & Design Engineer
Minimal drop between inlet and outlet	Site installation ease	Contractor
Large diameter outlet riser for inspection and maintenance	Easy maintenance access from grade	Maintenance Contractor & Site Owner

STANDARD STORMCEPTOR EF/EFO DRAWINGS

For standard details, please visit <http://www.imbriumsystems.com/stormwater-treatment-solutions/stormceptor-ef>

STANDARD STORMCEPTOR EF/EFO SPECIFICATION

For specifications, please visit <http://www.imbriumsystems.com/stormwater-treatment-solutions/stormceptor-ef>

STANDARD PERFORMANCE SPECIFICATION FOR “OIL GRIT SEPARATOR” (OGS) STORMWATER QUALITY TREATMENT DEVICE

PART 1 – GENERAL

1.1 WORK INCLUDED

This section specifies requirements for selecting, sizing, and designing an underground Oil Grit Separator (OGS) device for stormwater quality treatment, with third-party testing results and a Statement of Verification in accordance with ISO 14034 Environmental Management – Environmental Technology Verification (ETV).

1.2 REFERENCE STANDARDS & PROCEDURES

ISO 14034:2016 Environmental management – Environmental technology verification (ETV)

Canadian Environmental Technology Verification (ETV) Program’s **Procedure for Laboratory Testing of Oil-Grit Separators**

1.3 SUBMITTALS

1.3.1 All submittals, including sizing reports & shop drawings, shall be submitted upon request with each order to the contractor then forwarded to the Engineer of Record for review and acceptance. Shop drawings shall detail all OGS components, elevations, and sequence of construction.

1.3.2 Alternative devices shall have features identical to or greater than the specified device, including: treatment chamber diameter, treatment chamber wet volume, sediment storage volume, and oil storage volume.

1.3.3 Unless directed otherwise by the Engineer of Record, OGS stormwater quality treatment product substitutions or alternatives submitted within ten days prior to project bid shall not be accepted. All alternatives or substitutions submitted shall be signed and sealed by a local registered Professional Engineer, based on the exact same criteria detailed in Section 3, in entirety, subject to review and approval by the Engineer of Record.

PART 2 – PRODUCTS

2.1 OGS POLLUTANT STORAGE

The OGS device shall include a sump for sediment storage, and a protected volume for the capture and storage of petroleum hydrocarbons and buoyant gross pollutants. The minimum sediment & petroleum hydrocarbon storage capacity shall be as follows:

2.1.1	4 ft (1219 mm) Diameter OGS Units:	1.19 m ³ sediment / 265 L oil
	5 ft (1524 mm) Diameter OGS Units:	1.95 m ³ sediment / 420 L oil
	6 ft (1829 mm) Diameter OGS Units:	3.48 m ³ sediment / 609 L oil
	8 ft (2438 mm) Diameter OGS Units:	8.78 m ³ sediment / 1,071 L oil
	10 ft (3048 mm) Diameter OGS Units:	17.78 m ³ sediment / 1,673 L oil
	12 ft (3657 mm) Diameter OGS Units:	31.23 m ³ sediment / 2,476 L oil

PART 3 – PERFORMANCE & DESIGN

3.1 GENERAL

The OGS stormwater quality treatment device shall be verified in accordance with ISO 14034:2016 Environmental management – Environmental technology verification (ETV). The OGS stormwater quality treatment device shall remove oil, sediment and gross pollutants from stormwater runoff during frequent wet weather events, and retain these pollutants during less frequent high flow wet weather events below the insert within the OGS for later removal during maintenance. The Manufacturer shall have at least ten (10) years of local experience, history and success in engineering design, manufacturing and production and supply of OGS stormwater quality treatment device systems, acceptable to the Engineer of Record.

3.2 SIZING METHODOLOGY

The OGS device shall be engineered, designed and sized to provide stormwater quality treatment based on treating a minimum of 90 percent of the average annual runoff volume and a minimum removal of an annual average 60% of the sediment (TSS) load based on the Particle Size Distribution (PSD) specified in the sizing report for the specified device. Sizing of the OGS shall be determined by use of a minimum ten (10) years of local historical rainfall data provided by Environment Canada. Sizing shall also be determined by use of the sediment removal performance data derived from the ISO 14034 ETV third-party verified laboratory testing data from testing conducted in accordance with the Canadian ETV protocol Procedure for Laboratory Testing of Oil-Grit Separators, as follows:

3.2.1 Sediment removal efficiency for a given surface loading rate and its associated flow rate shall be based on sediment removal efficiency demonstrated at the seven (7) tested surface loading rates specified in the protocol, ranging 40 L/min/m² to 1400 L/min/m², and as stated in the ISO 14034 ETV Verification Statement for the OGS device.

3.2.2 Sediment removal efficiency for surface loading rates between 40 L/min/m² and 1400 L/min/m² shall be based on linear interpolation of data between consecutive tested surface loading rates.

3.2.3 Sediment removal efficiency for surface loading rates less than the lowest tested surface loading rate of 40 L/min/m² shall be assumed to be identical to the sediment removal efficiency at 40 L/min/m². No extrapolation shall be allowed that results in a sediment removal efficiency that is greater than that demonstrated at 40 L/min/m².

3.2.4 Sediment removal efficiency for surface loading rates greater than the highest tested surface loading rate of 1400 L/min/m² shall assume zero sediment removal for the portion of flow that exceeds 1400 L/min/m², and shall be calculated using a simple proportioning formula, with 1400 L/min/m² in the numerator and the higher surface loading rate in the denominator, and multiplying the resulting fraction times the sediment removal efficiency at 1400 L/min/m².

The OGS device shall also have sufficient annual sediment storage capacity as specified and calculated in Section 2.1.

3.3 CANADIAN ETV or ISO 14034 ETV VERIFICATION OF SCOUR TESTING

The OGS device shall have Canadian ETV or ISO 14034 ETV Verification of third-party scour testing conducted in accordance with the Canadian ETV Program's **Procedure for Laboratory Testing of Oil-Grit Separators**.

3.3.1 To be acceptable for on-line installation, the OGS device must demonstrate an average scour test effluent concentration less than 10 mg/L at each surface loading rate tested, up to and including 2600 L/min/m².

3.4 LIGHT LIQUID RE-ENTRAINMENT SIMULATION TESTING

The OGS device shall have Canadian ETV or ISO 14034 ETV Verification of completed third-party Light Liquid

Re-entrainment Simulation Testing in accordance with the Canadian ETV **Program's Procedure for Laboratory Testing of Oil-Grit Separators**, with results reported within the Canadian ETV or ISO 14034 ETV verification. This re-entrainment testing is conducted with the device pre-loaded with low density polyethylene (LDPE) plastic beads as a surrogate for light liquids such as oil and fuel. Testing is conducted on the same OGS unit tested for sediment removal to assess whether light liquids captured after a spill are effectively retained at high flow rates.

3.4.1 For an OGS device to be an acceptable stormwater treatment device on a site where vehicular traffic occurs and the potential for an oil or fuel spill exists, the OGS device must have reported verified performance results of greater than 99% cumulative retention of LDPE plastic beads for the five specified surface loading rates (ranging 200 L/min/m² to 2600 L/min/m²) in accordance with the Light Liquid Re-entrainment Simulation Testing within the Canadian ETV Program's **Procedure for Laboratory Testing of Oil-Grit Separators**. However, an OGS device shall not be allowed if the Light Liquid Re-entrainment Simulation Testing was performed with screening components within the OGS device that are effective at retaining the LDPE plastic beads, but would not be expected to retain light liquids such as oil and fuel.

Appendix E

Geotechnical Information



Geotechnical Investigation Report 49 Folkard Lane Picton, Ontario

Cambium Reference No.: 6563-001

August 24, 2017

Prepared for: G.D. Jewell Engineering Inc.



Cambium Inc.

710 Arlington Park Place
Kingston, Ontario
K7M 7N7

Telephone: (866) 217.7900
Facsimile: (705) 742.7907

cambium-inc.com



TABLE OF CONTENTS

1.0	INTRODUCTION.....	1
2.0	METHODOLOGY.....	2
2.1	BOREHOLE INVESTIGATION	2
2.2	PHYSICAL LABORATORY TESTING	2
3.0	SUBSURFACE CONDITIONS	3
3.1	TOPSOIL.....	3
3.2	OVERBURDEN.....	3
3.3	BEDROCK	4
3.4	GROUNDWATER	4
4.0	GEOTECHNICAL CONSIDERATIONS	5
4.1	SITE PREPARATION	5
4.2	EXCAVATIONS.....	5
4.3	DEWATERING.....	5
4.4	BACKFILL AND COMPACTION	6
4.5	FOUNDATION DESIGN	6
4.5.1	Frost Penetration.....	7
4.6	FLOOR SLABS	7
4.7	BURIED UTILITIES.....	7
4.8	LATERAL EARTH PRESSURE	8
4.9	PAVEMENT DESIGN	8
4.10	DESIGN REVIEW AND INSPECTIONS.....	9
5.0	CLOSING.....	10



LIST OF APPENDED FIGURES

Figure 1 Borehole Location Plan

LIST OF INSERTED TABLES

Table 1	Particle Size Distribution Results – Overburden	3
Table 2	Bedrock Termination Depth	4
Table 3	Recommended Minimum Pavement Structure	9

LIST OF APPENDICES

Appendix A	Borehole Logs
Appendix B	Physical Laboratory Testing Results



1.0 INTRODUCTION

Cambium Inc. (Cambium) was retained by G.D. Jewell Engineering Inc. (Client) to complete a geotechnical investigation in support of the design and construction of a residential subdivision in Picton, Ontario (Site) located at 49 Folkard Lane. In addition, the investigation is required as part of the due diligence process to determine if the property is well suited for the proposed residential contraction.

The property to be developed is currently a mixture of tall grass and small trees which cover a majority of the property. The general topography is relatively flat with a slight dip from west to east towards Picton Bay with the property also being of lower elevation in comparison to County Road 49.

The geotechnical investigation was required to confirm the subsurface conditions at the Site in order to provide geotechnical design parameters as input into the design and construction of the proposed residential units, site servicing, and road construction. A Site Plan showing borehole locations is included as Figure 1 of this report.

This report presents the methodology and findings of the geotechnical investigation at the Site and addresses requirements and constraints for the design and construction of the buildings, pavement structure, and underground servicing.



2.0 METHODOLOGY

2.1 BOREHOLE INVESTIGATION

A borehole investigation was conducted on August 4, 2017 to assess subsurface conditions at the Site. A total of nine (9) boreholes, designated as BH101-17 through BH109-17, were advanced throughout the Site. The boreholes extended to bedrock refusal depth across the entirety of the site at depths ranging from 0.25 m to 1.45 m below ground surface (mbgs). The location of each borehole was identified in the field with GPS coordinates from a handheld device with all borehole locations shown in Figure 1.

Drilling and sampling was completed using a track-mounted drill rig operating under the supervision of a Cambium technician. The boreholes were advanced to the sampling depths by means of continuous flight solid stem augers with 50 mm O.D. split spoon samplers. Standard Penetration Test (SPT) N values were recorded for the sampled internals as the number of blows required to drive a split spoon sampler 305 mm in to the soil, using a 63.5 kg drop hammer falling 750 mm, as per ASTM D1586 procedures. The SPT N values are used in this report to assess consistency of cohesive soils and relative density of non-cohesive soils. Soil samples were collected at approximately 0.75 m intervals to 3.0 m depth. The encountered soil units were logged in the field using visual and tactile methods, and samples were placed in labelled plastic bags for transport, future reference, possible laboratory testing, and storage. Open boreholes were checked for groundwater and general stability prior to backfilling.

Borehole logs are provided in Appendix A while Site soil and groundwater conditions are described and geotechnical recommendations are discussed in the following sections of this report.

2.2 PHYSICAL LABORATORY TESTING

Physical laboratory testing, including four (4) particle size distribution analyses (LS-702, 705) was completed on selected soil samples to confirm textural classification and to assess geotechnical parameters. Natural moisture content testing (LS-701) was completed on all retrieved soil samples. Results are presented in Appendix B and are discussed in Section 3.0.



3.0 SUBSURFACE CONDITIONS

The subsurface conditions at the Site predominantly consist of a layer of surficial topsoil overlying various layers of sand to silty sand to silt with traces of clay, gravel, and cobbles consistent with till like deposits. These soils were encountered throughout the borehole locations with varying termination depth on presumed limestone bedrock. The borehole locations are shown on Figure 1 and the individual soil units are described in detail below.

3.1 TOPSOIL

In all of the boreholes advanced on the Site, surficial topsoil was encountered across the entirety of the site. The topsoil ranged in thickness from 100 mm to approximately 450 mm. The topsoil mainly consisted of moderately rooted sandy silt to silt, and was very loose to loose.

Assessments of organic matter content or other topsoil quality tests were beyond the scope of this study.

3.2 OVERBURDEN

Underlying the topsoil across the entirety of the site was intermittent layers of sand to sandy silt to silt material with varying amounts of clay and gravel. This material extended to the borehole termination depths between 0.25 m and 1.45 mbgs on presumed limestone bedrock. Based on these observations the general soil texture resembles a glacial till. The sand to silty sand soils varied in colour from light brown to brown and was dry to moist at the time of the investigation with isolated regions of moist conditions. Based on laboratory analysis the moisture content ranged from 7.0% to 29.2%.

Based on SPT values generally ranging from 5 to 29 blows per 305 mm of penetration, the sand to sandy silt to silt has a loose to compact relative density. However, most

Laboratory particle size distribution analyses were completed on four (4) samples of the glacial till overburden material. The analytical results are shown on the borehole logs, included in Appendix A., and are summarized in Table 1 based on the Unified Soil Classification System (USCS).

Table 1 Particle Size Distribution Results – Overburden

Borehole	Depth	Soil	% Gravel	% Sand	% Silt	% Clay
BH103-17	0.0 m – 0.6 m	Silty Sand	7	65	28	
BH104-17	0.8 m – 1.2 m	Sand and Silt	16	48	36	
BH105-17	0.8 m – 1.2 m	Silty Sand	3	72	20	5
BH108-17	0.0 m – 0.6 m	Sand and Silt	1	47	40	12



3.3 BEDROCK

Bedrock was encountered in all boreholes and terminated at depths ranging from 0.25 mbgs to 1.45 mbgs. The bedrock is presumed to consist of limestone with a weathered upper surface based on the ability for the solid stem auger to penetrate the limestone. Depth to bedrock is shown in Table 2 below.

Table 2 Bedrock Termination Depth

Borehole ID	Depth to Bedrock
BH101-17	0.43 m
BH102-17	0.25 m
BH103-17	0.56 m
BH104-17	1.45 m
BH105-17	1.20 m
BH106-17	0.75 m
BH107-17	0.51 m
BH108-17	0.60 m
BH109-17	1.06 m

3.4 GROUNDWATER

Groundwater was not encountered across the entirety of the site and is expected to be housed within the limestone bedrock at an elevation close to that of the adjacent Picton Bay. It should be noted that soil moisture and groundwater levels at the Site may fluctuate seasonally and in response to climatic events.



4.0 GEOTECHNICAL CONSIDERATIONS

The following recommendations are based on the borehole information and are intended to assist designers. Recommendations should not be construed as providing instructions to contractors, who should form their own opinions about site conditions. It is possible that subsurface conditions beyond the borehole locations may vary from those observed. If significant variations are found before or during construction, Cambium should be contacted so that we can reassess our findings, if necessary.

4.1 SITE PREPARATION

Any existing topsoil or soils identified with organic content at the Site should be excavated and removed from beneath any areas of the Site to be developed.

Based on the shallow nature of the bedrock at this site and the instability of the overburden material it is expected that all residential building structures will be founded on limestone bedrock above the existing groundwater table.

The near surface clayey silt to silty sand soils can be very unstable if they are wet or saturated. Such conditions are common in the spring and late fall. Under these conditions, temporary use of granular fill, and possible reinforcing geotextiles, may be required to prevent severe rutting on construction access routes.

4.2 EXCAVATIONS

Temporary excavations must be carried out in accordance with the latest edition of the Occupational Health and Safety Act (OHSA). The generally compact native sand to sandy silt soils above the groundwater table may be classified as Type 2 soils in accordance with OHSA, with vertical sides to a depth of 1.2 m and then cut with side slopes no steeper than 1H:1V beyond 1.2 m depth if required. Below the groundwater table if encountered, these soils may be classified as Type 3 soils, with unsupported side slopes no steeper than 1H:1V. Shallow, temporary excavations into the limestone bedrock at the site can have vertical side slopes.

Excavation side slopes should be protected from exposure to precipitation and associated ground surface runoff and should be inspected regularly for signs of instability. If localized instability is noted during excavation or if wet conditions are encountered, the side slopes should be flattened as required to maintain safe working conditions or the excavation sidewalls must be fully supported (shored).

The upper 0.3 m of limestone bedrock at the site can likely be removed by a large excavator. Any deeper excavations would require a hoe ram and/or blasting.

4.3 DEWATERING

Across a majority of the Site, groundwater was not encountered and is expected to be housed within the bedrock. Based on these observations groundwater seepage is not expected to be an issue during residential foundation



construction but may be encountered during the installation of underground services into bedrock. If groundwater seepage is encountered it should be manageable with filtered sumps and pumps and a Permit to Take Water (PTTW) from the Ministry of the Environment and Climate Change (MOECC) will not be required. It is noted that the elevation of the groundwater table will vary due to seasonal conditions and in response to heavy precipitation events but is expected to be below proposed foundation depths.

4.4 BACKFILL AND COMPACTION

Excavated non-organic, native overburden sand to sandy silt soils from the site may be appropriate for use as fill below grading and parking areas, provided that the actual or adjusted moisture content at the time of construction is within a range that permits compaction to required densities. Some moisture content adjustments may be required depending upon seasonal conditions. Geotechnical inspections and testing of engineered fill are required to confirm acceptable quality.

Any engineered fill for foundations should be placed in maximum 200 mm thick lifts and should be compacted to a minimum of 100% of standard Proctor maximum dry density (SPMDD). If engineered fill is being placed for general site backfill and grading then compaction to 98% is applicable. If conditions are wet at the time of construction, compaction of granular fill may not be possible and 19 mm diameter crushed clear stone wrapped in a geotextile filter fabric (Terrafix 270R or equivalent) should be used in place of engineered fill.

Foundation wall backfill should consist of free-draining imported granular material. Most of the native site soils are too fine-grained to provide proper drainage, and as such this should be accomplished using well graded Granular B Type 1 material complying with OPSS 1010. If a drainage layer membrane is used against the foundation then Granular B Type 1 material will not be required and the native site soils will be sufficient. Backfill should be placed in lifts not exceeding 250 mm in thickness and compacted to 98% of SPMDD. Placement of engineered fill should be verified by onsite compaction testing during construction.

4.5 FOUNDATION DESIGN

Assuming that the Site is prepared as outlined above, all building foundations will be founded on limestone bedrock encountered across the entirety of the Site and is competent to support the structures on conventional strip and spread footings. The limestone bedrock may be designed for an allowable bearing capacity of 900 kPa at ultimate limit state (ULS). The settlement potential on bedrock will be negligible assuming the upper weathered portion of the bedrock is removed and minimal clay seams are identified during this process.

The quality of the rock should be inspected by Cambium during construction, prior to constructing the footings, to confirm bearing capacity estimates. Any loose, weathered rock present at footing depth should be scraped and cleaned to provide a smooth bearing surface for footing placement.



4.5.1 FROST PENETRATION

Based on climate data and design charts, the maximum frost penetration at the Site is estimated at 1.2 m.

Footings for the proposed structures should be situated at or below this depth for frost protection or should be protected. As long as footings are placed on competent limestone bedrock free from weathering and with a clean surface, frost penetration is not expected to be an issue based on the competency of the bedrock in the region. If heavily weathered surface or multiple clay seams are identified frost protection in the form of granular back fill or insulation will be required.

It is assumed that the pavement structure thickness will be less than 1.2 m, so grading and drainage are important for good pavement performance and life expectancy. The construction of any underground services should be located below this depth or be appropriately insulated.

4.6 FLOOR SLABS

Inorganic native soils at the Site are considered not competent to support floor slab loads and must also be founded on limestone bedrock or engineered fill extending to bedrock. To create a stable working surface and to distribute loadings, all slabs-on-grade should be constructed on a minimum of 200 mm of OPSS 1010 Granular A compacted to 98 percent of SPMDD with additional engineered fill placed and compacted to 98% SPMDD to raise grades as required.

4.7 SUBDRAINAGE

Groundwater seepage was not encountered in the boreholes at the time of investigation, but it should be noted that groundwater levels are affected by seasonal climatic conditions, as such, groundwater levels are expected to be at higher levels during seasonally wet periods, and the bedrock can potentially block groundwater infiltration during wetter seasons. As such, geotextile wrapped perforated pipe subdrains set in a trench of clear stone and connected to a sump or other frost-free positive outlet are recommended around all footings and underneath the floor slabs. As the subgrade was a silty material and given the encountered ground water, it is recommended that a geotextile (Terrafix 270R or equivalent) is placed between the subgrade and the clear stone to prevent erosion of the subgrade soils.

4.8 BURIED UTILITIES

Trench excavations should generally consider limestone bedrock conditions which can be excavated with unsupported side slopes. If encountered, groundwater should be controllable using filtered sumps and pumps within the excavations.



The bedding and cover material for any services should consist of OPSS 1010-3 Granular A or B Type II, placed in accordance with pertinent Ontario Provincial Standard Drawings (OPSD 802.013). The bedding and cover material shall be placed in maximum 200 mm thick lifts and should be compacted to at least 98% of SPMDD. The cover material shall be a minimum of 300 mm over the top of the pipe and compacted to 95% SPMDD, taking care not to damage the utility pipes during compaction. If groundwater is present during placement of bedding material for utilities then 19 mm clear stone shall be used in place of granular material to ensure adequate compaction under wet conditions.

4.9 LATERAL EARTH PRESSURE

Unfactored lateral earth pressure coefficients (K) for foundation and retaining wall design are provided below. It is assumed that potential lateral loads will result from cohesionless, frictional materials, such as granular backfill.

Ko (at rest)	0.42
Ka (active)	0.27
Kp (passive)	3.7

The following formula may be used to calculate active lateral thrust (Pa) on yielding retaining structures;

$$P_a = (H/2)(K_a)(\gamma H + 2q)$$

where,

H = Height of retaining structure (m)

γ = unit weight of retained soil (kN/m³)

q = surcharge (kPa)

A unit weight of 22 kN/m³ should be assumed for compacted granular backfill loadings.

4.10 PAVEMENT DESIGN

The performance of the pavement is dependent upon proper subgrade preparation. All topsoil and organic materials should be removed down to native material and backfilled with approved engineered fill or native material, compacted to 98 percent SPMDD. The subgrade should be proof rolled and inspected by a Geotechnical Engineer. Any areas where boulders, rutting, or appreciable deflection is noted should be subexcavated and replaced with suitable fill. The fill should be compacted to at least 98 percent SPMDD.

The recommended pavement structure should meet the Ministry standards for parking and driving areas and should, as a minimum, consist of the pavement layers identified in Table 3. The light duty pavement structure is intended for parking areas while the heavy duty pavement structure is appropriate for areas where heavy traffic is anticipated.



Table 3 Recommended Minimum Pavement Structure

Pavement Layer	Light Duty	Heavy Duty
Surface Course Asphalt	50 mm HL3 or HL4	40 mm HL3 or HL4
Binder Course Asphalt		50 mm HL8
Granular Base	150 mm OPSS 1010 Granular A	150 mm OPSS 1010 Granular A
Granular Subbase	300 mm OPSS 1010 Granular B	300 mm OPSS 1010 Granular B

Material and thickness substitutions must be approved by the Design Engineer.

The thickness of the subbase layer could be increased at the discretion of the Engineer, to accommodate site conditions at the time of construction, including soft or weak subgrade soil replacement. The heavy duty classification is recommended for the majority of roadways at this site and is based off of the minimum standards set out by Prince Edward County.

Compaction of the subgrade should be verified by the Engineer prior to placing the granular fill. Granular layers should be placed in 150 mm maximum loose lifts and compacted to at least 98 percent of SPMDD (ASTM D698) standard. The granular materials specified should conform to OPSS standards, as confirmed by appropriate materials testing.

The final asphalt surface should be sloped at a minimum of 2 percent to shed runoff. Abutting pavements should be sawcut to provide clean vertical joints with new pavement areas.

4.11 DESIGN REVIEW AND INSPECTIONS

Cambium should be retained to complete testing and inspections during construction operations to examine and approve subgrade conditions, placement and compaction of fill materials, granular base courses, and asphaltic concrete.

We should be contacted to review and approve design drawings, prior to tendering or commencing construction, to ensure that all pertinent geotechnical-related factors have been addressed. It is important that onsite geotechnical supervision be provided at this site for excavation and backfill procedures, deleterious soil removal, subgrade inspections and compaction testing.



5.0 CLOSING

We trust that the information contained in this report meets your current requirements. If you have questions or comments regarding this document, please do not hesitate to contact the undersigned at (705) 742-7900 ext. 332.

Respectfully submitted,

CAMBIUM INC.

Kyle Thompson, BScE, EIT
Project Coordinator

Stuart Baird, P.Eng.
Senior Project Manager

SEB/kwt

P:\6500 to 6599\6563-001 G.D. Jewell Engineering - Geotechnical Investigation - 49 Folkard Lane, Picton\Deliverables\2017-08-17 RPT 49 Folkard Lane Geotech.docx





Appended Figures



O:\GIS\project_L\MC\6500-6599\6563-001 G.D. Jewell Engineering - Geotechnical Investigation - 49 Folkard Lane, Picton\2017-08-04 FIG 1 - Borehole Location Plan.mxd



GEOTECHNICAL INVESTIGATION

G.D. JEWELL ENGINEERING
49 Folkard Lane
Picton, Ontario

LEGEND

-  Borehole Location
-  Site Area (approximate)

Notes:
 - Base mapping features are © Queen's Printer of Ontario, 2017 (this does not constitute an endorsement by the Ministry of Natural Resources or the Ontario Government).
 - Distances on this plan are in metres and can be converted to feet by dividing by 0.3048.
 - Cambium Inc. makes every effort to ensure this map is free from errors but cannot be held responsible for any damages due to error or omissions. This map should not be used for navigation or legal purposes. It is intended for general reference use only.



P.O. Box 325, 52 Hunter Street East
Peterborough, Ontario, K9H 1G5
Tel: (705) 742.7900 Fax: (705) 742.7907
www.cambium-inc.com

BOREHOLE LOCATION PLAN

Project No.: 6563-001	Date: August 2017
Scale: 1: 1,500	Projection: NAD 1983 UTM Zone 18N
Created by: TLC	Checked by: KWT
Figure: 1	



Appendix A

Borehole Logs



Peterborough
 Barrie
 Oshawa
 Kingston
 T: 866-217-7900
 www.cambium-inc.com

Log of Borehole:

BH101-17

Page 1 of 1

Client: G.D. Jewell Engineering Inc.
Contractor: Canadian Environmental Drilling
Location: 49 Folkard Lane, Picton, Ontario

Project Name: Geotechnical Investigation
Method: Solid Stem Auger
UTM: 18T 328983 N 4877208 E

Project No.: 6563-001
Date Completed: August 4, 2017
Elevation:

SUBSURFACE PROFILE				SAMPLE												
Elevation (m)	Depth	Lithology	Description	Number	Type	% Recovery	SPT (N)	% Moisture			SPT (N)				Well Installation	Remarks
								25	50	75	10	20	30	40		
0	0		TOPSOIL: Brown sandy silt topsoil, some organics, very loose, moist	1	SS	100	50/125	•								
			Borehole terminated at 0.43 m on auger refusal of presumed bedrock													Borehole open and dry upon completion
-1	1															
-2	2															

Logged By: M. Smit

Input By: K. Thompson



**Peterborough
Barrie
Oshawa
Kingston**
T: 866-217-7900
www.cambium-inc.com

Log of Borehole:

BH102-17

Page 1 of 1

Client: G.D. Jewell Engineering Inc.
Contractor: Canadian Environmental Drilling
Location: 49 Folkard Lane, Picton, Ontario

Project Name: Geotechnical Investigation
Method: Solid Stem Auger
UTM: 18T 328925 N 4877207 E

Project No.: 6563-001
Date Completed: August 4, 2017
Elevation:

SUBSURFACE PROFILE				SAMPLE												
Elevation (m)	Depth	Lithology	Description	Number	Type	% Recovery	SPT (N)	% Moisture			SPT (N)				Well Installation	Remarks
								25	50	75	10	20	30	40		
0	0		TOPSOIL: Brown silt topsoil, some sand, some organics, very loose, dry to moist	1	SS	80	50/100	•								
			Borehole terminated at 0.25 m on auger refusal of presumed bedrock													Borehole open and dry upon completion
-1	1															
-2	2															

Logged By: M. Smit

Input By: K. Thompson



Peterborough
 Barrie
 Oshawa
 Kingston
 T: 866-217-7900
 www.cambium-inc.com

Log of Borehole:

BH103-17

Page 1 of 1

Client: G.D. Jewell Engineering Inc.
Contractor: Canadian Environmental Drilling
Location: 49 Folkard Lane, Picton, Ontario

Project Name: Geotechnical Investigation
Method: Solid Stem Auger
UTM: 18T 328836 N 4877208 E

Project No.: 6563-001
Date Completed: August 4, 2017
Elevation:

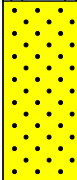
SUBSURFACE PROFILE				SAMPLE												
Elevation (m)	Depth	Lithology	Description	Number	Type	% Recovery	SPT (N)	% Moisture			SPT (N)				Well Installation	Remarks
								25	50	75	10	20	30	40		
0	0		TOPSOIL: Brown silty sand topsoil, some organics, very loose to loose, dry to moist													
			SAND: Light brown sand, some silt, very loose to loose, dry to moist	1	SS	58	5	•								SS-01 GSA: Gravel 7% Sand 65% Silt & Clay 28%
			Borehole terminated at 0.56 m on auger refusal of presumed bedrock													Borehole open and dry upon completion
-1	1															
-2	2															

Logged By: M. Smit

Input By: K. Thompson



Peterborough
 Barrie
 Oshawa
 Kingston
 T: 866-217-7900
 www.cambium-inc.com

Log of Borehole:

BH105-17

Page 1 of 1

Client: G.D. Jewell Engineering Inc.
Contractor: Canadian Environmental Drilling
Location: 49 Folkard Lane, Picton, Ontario

Project Name: Geotechnical Investigation
Method: Solid Stem Auger
UTM: 18T 328864 N 4877109 E

Project No.: 6563-001
Date Completed: August 4, 2017
Elevation:

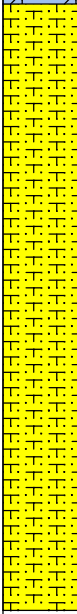
SUBSURFACE PROFILE				SAMPLE												
Elevation (m)	Depth	Lithology	Description	Number	Type	% Recovery	SPT (N)	% Moisture			SPT (N)				Well Installation	Remarks
								25	50	75	10	20	30	40		
0	0		TOPSOIL: Brown silt topsoil, some sand, trace clay, some organics, very loose, dry to moist													
			SILTY SAND: Light brown silty sand, trace clay, loose to compact, dry to moist	1	SS	46	5									
-1	1			2	SS	81	13									
			Borehole terminated at 1.2 m on auger refusal of presumed bedrock													
-2	2															

SS-02 GSA:
 Gravel 3%
 Sand 72%
 Silt 20%
 Clay 5%

Borehole open and dry upon completion

Logged By: M. Smit

Input By: K. Thompson



Peterborough
 Barrie
 Oshawa
 Kingston
 T: 866-217-7900
 www.cambium-inc.com

Log of Borehole:

BH106-17

Page 1 of 1

Client: G.D. Jewell Engineering Inc.
Contractor: Canadian Environmental Drilling
Location: 49 Folkard Lane, Picton, Ontario

Project Name: Geotechnical Investigation
Method: Solid Stem Auger
UTM: 18T 328903 N 4877125 E

Project No.: 6563-001
Date Completed: August 4, 2017
Elevation:

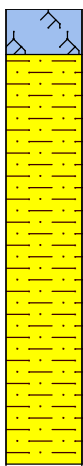
SUBSURFACE PROFILE			SAMPLE												
Elevation (m)	Depth	Lithology	Description	Number	Type	% Recovery	SPT (N)	% Moisture			SPT (N)			Well Installation	Remarks
								25	50	75	10	20	30		
0	0		<p>TOPSOIL: Brown silt topsoil, trace clay, some organics, very loose, dry to moist</p> <p>SILT: Brown silt, some sand, trace clay, loose to compact, dry to moist</p>	1	SS	42	6	•							
			Borehole terminated at 0.75 m on auger refusal of presumed bedrock												Borehole open and dry upon completion
-1	1														
-2	2														

Logged By: M. Smit

Input By: K. Thompson



Peterborough
 Barrie
 Oshawa
 Kingston
 T: 866-217-7900
 www.cambium-inc.com

Log of Borehole:

BH107-17

Page 1 of 1

Client: G.D. Jewell Engineering Inc.
Contractor: Canadian Environmental Drilling
Location: 49 Folkard Lane, Picton, Ontario

Project Name: Geotechnical Investigation
Method: Solid Stem Auger
UTM: 18T 328940 N 4877100 E

Project No.: 6563-001
Date Completed: August 4, 2017
Elevation:

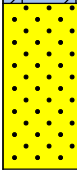
SUBSURFACE PROFILE				SAMPLE												
Elevation (m)	Depth	Lithology	Description	Number	Type	% Recovery	SPT (N)	% Moisture			SPT (N)				Well Installation	Remarks
								25	50	75	10	20	30	40		
0	0		TOPSOIL: Brown silt topsoil, some sand, some organics, very loose, dry to moist	1	SS	47	4	•								
			SAND: Light brown sand, some silt, loose, dry to moist													
			Borehole terminated at 0.51 m on auger refusal of presumed bedrock													Borehole open and dry upon completion
-1	1															
-2	2															

Logged By: M. Smit

Input By: K. Thompson



Peterborough
 Barrie
 Oshawa
 Kingston
 T: 866-217-7900
 www.cambium-inc.com

Log of Borehole:

BH108-17

Page 1 of 1

Client: G.D. Jewell Engineering Inc.
Contractor: Canadian Environmental Drilling
Location: 49 Folkard Lane, Picton, Ontario

Project Name: Geotechnical Investigation
Method: Solid Stem Auger
UTM: 18T 328953 N 4877071 E

Project No.: 6563-001
Date Completed: August 4, 2017
Elevation:

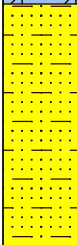
SUBSURFACE PROFILE			SAMPLE													
Elevation (m)	Depth	Lithology	Description	Number	Type	% Recovery	SPT (N)	% Moisture			SPT (N)				Well Installation	Remarks
								25	50	75	10	20	30	40		
0	0		TOPSOIL: Brown silt topsoil, some clay, some organics, loose, moist													SS-01 GSA: Gravel 1% Sand 47% Silt 40% Clay 12%
			SAND AND SILT: Light brown sand and silt, some clay, loose, dry to moist	1	SS	67	5	•								
			Borehole terminated at 0.60 m on auger refusal of presumed bedrock													
-1	1															
-2	2															

Logged By: M. Smit

Input By: K. Thompson



**Peterborough
Barrie
Oshawa
Kingston**
T: 866-217-7900
www.cambium-inc.com

Log of Borehole:

BH109-17

Page 1 of 1

Client: G.D. Jewell Engineering Inc.
Contractor: Canadian Environmental Drilling
Location: 49 Folkard Lane, Picton, Ontario

Project Name: Geotechnical Investigation
Method: Solid Stem Auger
UTM: 18T 328885 N 4877051 E

Project No.: 6563-001
Date Completed: August 4, 2017
Elevation:

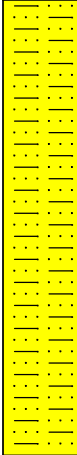
SUBSURFACE PROFILE				SAMPLE												
Elevation (m)	Depth	Lithology	Description	Number	Type	% Recovery	SPT (N)	% Moisture			SPT (N)				Well Installation	Remarks
								25	50	75	10	20	30	40		
0	0		TOPSOIL: Brown silt topsoil, some sand, some organics, very loose to loose, dry to moist													
			SANDY SILT: Brown sandy silt, trace clay, loose, dry to moist	1	SS	75	6									
			- No clay present													
				2	SS	57	50/25									
			Borehole terminated at 1.06 m on auger refusal of presumed bedrock													
																Borehole open and dry upon completion
-1	1															
-2	2															

Logged By: M. Smit

Input By: K. Thompson



Appendix B

Physical Laboratory Testing Results



Grain Size Distribution Chart

Project Number: 6563-001 **Client:** G.D. Jewell Engineering
Project Name: 49 Folkard Lane
Sample Date: August 4, 2017 **Sampled By:** Michael Smit - Cambium Inc.
Location: BH 103-17 SS 1 **Depth:** 0 m to 0.6 m **Lab Sample No:** S-17-0658

UNIFIED SOIL CLASSIFICATION SYSTEM					
CLAY & SILT (<0.075 mm)	SAND (<4.75 mm to 0.075 mm)			GRAVEL (>4.75 mm)	
	FINE	MEDIUM	COARSE	FINE	COARSE

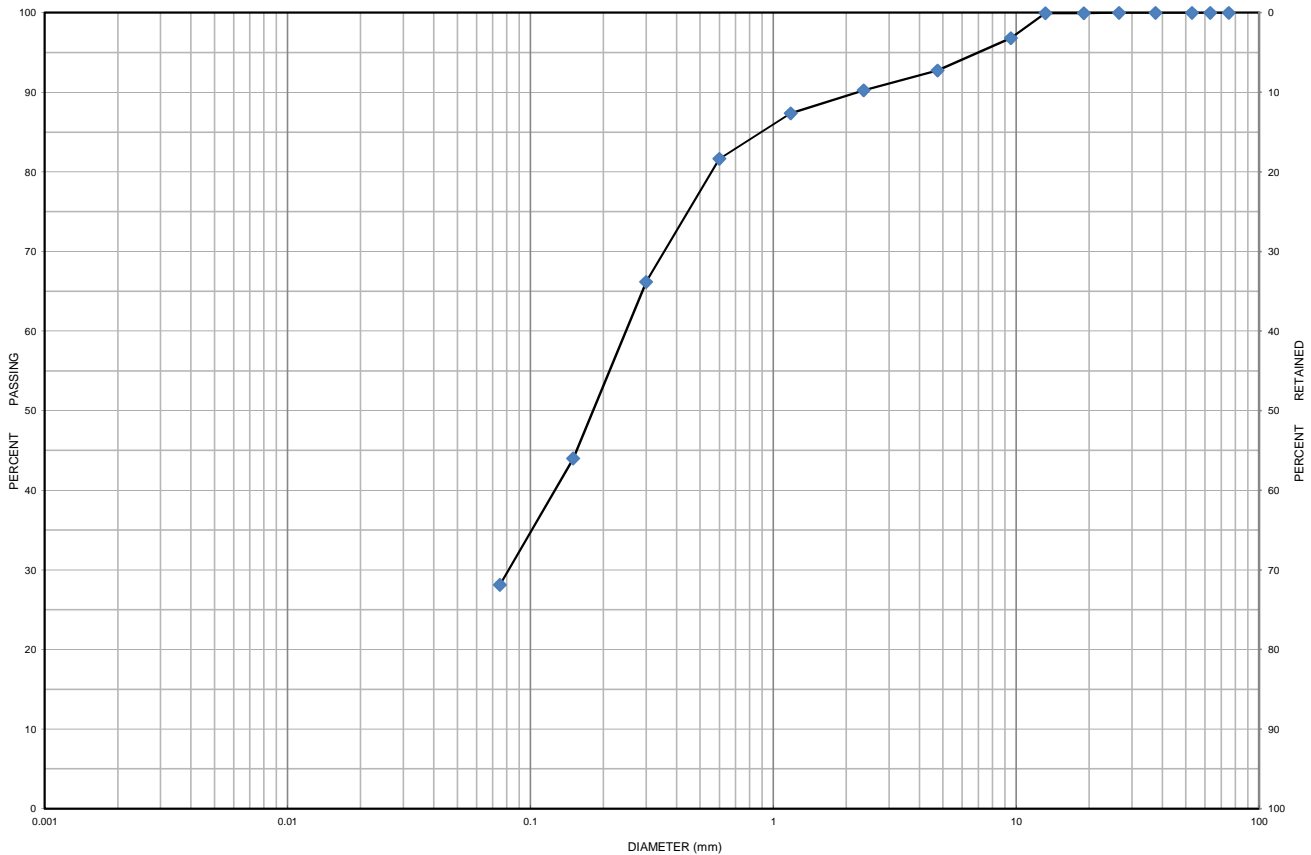

MIT SOIL CLASSIFICATION SYSTEM								
CLAY	SILT	FINE	MEDIUM	COARSE	FINE	MEDIUM	COARSE	BOULDERS
		SAND			GRAVEL			

Location	Sample No.	Depth	Gravel	Sand	Silt	Clay	Moisture
BH 103-17	SS 1	0 m to 0.6 m	7	65	28		10.0
Description		Classification	D ₆₀	D ₃₀	D ₁₀	C _u	C _c
Silty Sand trace Gravel		SM	0.250	0.082	-	-	-

Issued By: *John Baird*
 (Senior Project Manager)

Date Issued: August 22, 2017



Grain Size Distribution Chart

Project Number: 6563-001 **Client:** G.D. Jewell Engineering
Project Name: 49 Folkard Lane
Sample Date: August 4, 2017 **Sampled By:** Michael Smit - Cambium Inc.
Location: BH 104-17 SS 2 **Depth:** 0.8 m to 1.2 m **Lab Sample No:** S-17-660

UNIFIED SOIL CLASSIFICATION SYSTEM					
CLAY & SILT (<0.075 mm)	SAND (<4.75 mm to 0.075 mm)			GRAVEL (>4.75 mm)	
	FINE	MEDIUM	COARSE	FINE	COARSE

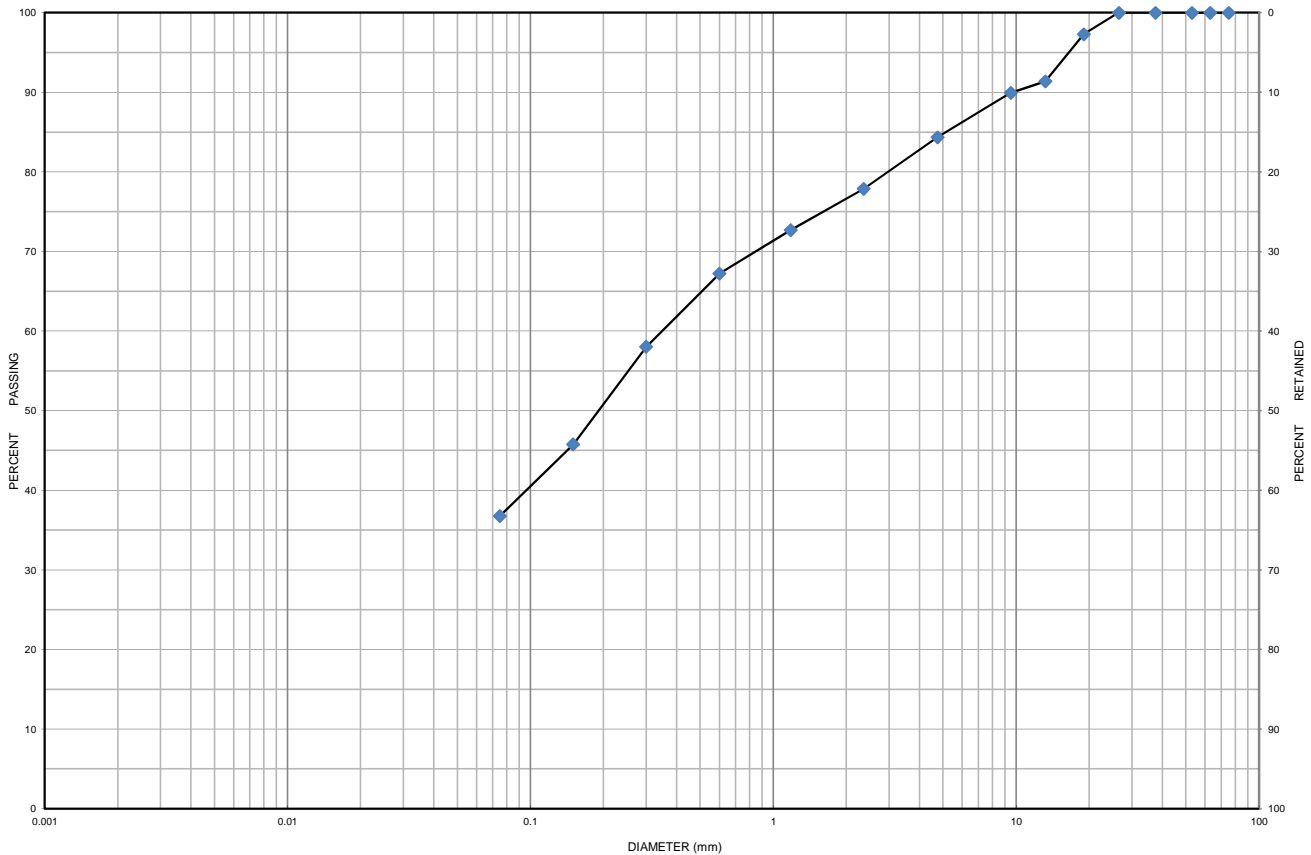

MIT SOIL CLASSIFICATION SYSTEM								
CLAY	SILT	FINE	MEDIUM	COARSE	FINE	MEDIUM	COARSE	BOULDERS
		SAND			GRAVEL			

Location	Sample No.	Depth	Gravel	Sand	Silt	Clay	Moisture
BH 104-17	SS 2	0.8 m to 1.2 m	16	48	36		7.0
Description		Classification	D ₆₀	D ₃₀	D ₁₀	C _u	C _c
Sand and Silt some Gravel		SP-ML	0.350	-	-	-	-

Issued By: *John Baird*
 (Senior Project Manager)

Date Issued: August 22, 2017



Grain Size Distribution Chart

Project Number: 6563-001 **Client:** G.D. Jewell Engineering
Project Name: 49 Folkard Lane
Sample Date: August 4, 2017 **Sampled By:** Michael Smit - Cambium Inc.
Location: BH 105-17 SS 2 **Depth:** 0.8 m to 1.2 m **Lab Sample No:** S-17-661

UNIFIED SOIL CLASSIFICATION SYSTEM					
CLAY & SILT (<0.075 mm)	SAND (<4.75 mm to 0.075 mm)			GRAVEL (>4.75 mm)	
	FINE	MEDIUM	COARSE	FINE	COARSE

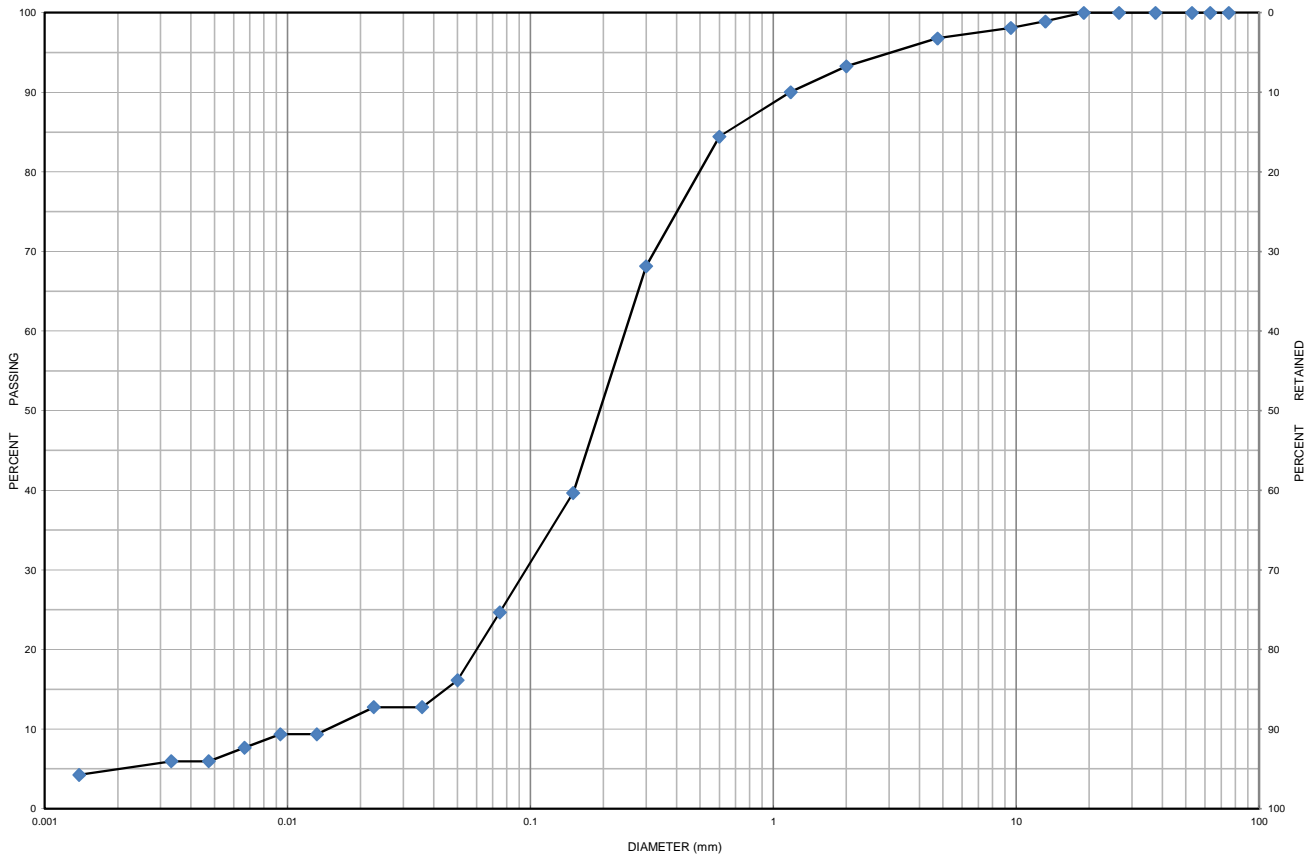

MIT SOIL CLASSIFICATION SYSTEM								
CLAY	SILT	FINE	MEDIUM	COARSE	FINE	MEDIUM	COARSE	BOULDERS
		SAND			GRAVEL			

Location	Sample No.	Depth	Gravel	Sand	Silt	Clay	Moisture
BH 105-17	SS 2	0.8 m to 1.2 m	3	72	25		9.3
Description		Classification	D ₆₀	D ₃₀	D ₁₀	C _u	C _c
Silty Sand trace Clay trace Gravel		SM	0.250	0.097	0.016	15.63	2.35

Issued By: *John Baird*
 (Senior Project Manager)

Date Issued: August 22, 2017



Grain Size Distribution Chart

Project Number: 6563-001 **Client:** G.D. Jewell Engineering
Project Name: 49 Folkard Lane
Sample Date: August 4, 2017 **Sampled By:** Michael Smit - Cambium Inc.
Location: BH 108-17 SS 1 **Depth:** 0 m to 0.6 m **Lab Sample No:** S-17-659

UNIFIED SOIL CLASSIFICATION SYSTEM					
CLAY & SILT (<0.075 mm)	SAND (<4.75 mm to 0.075 mm)			GRAVEL (>4.75 mm)	
	FINE	MEDIUM	COARSE	FINE	COARSE

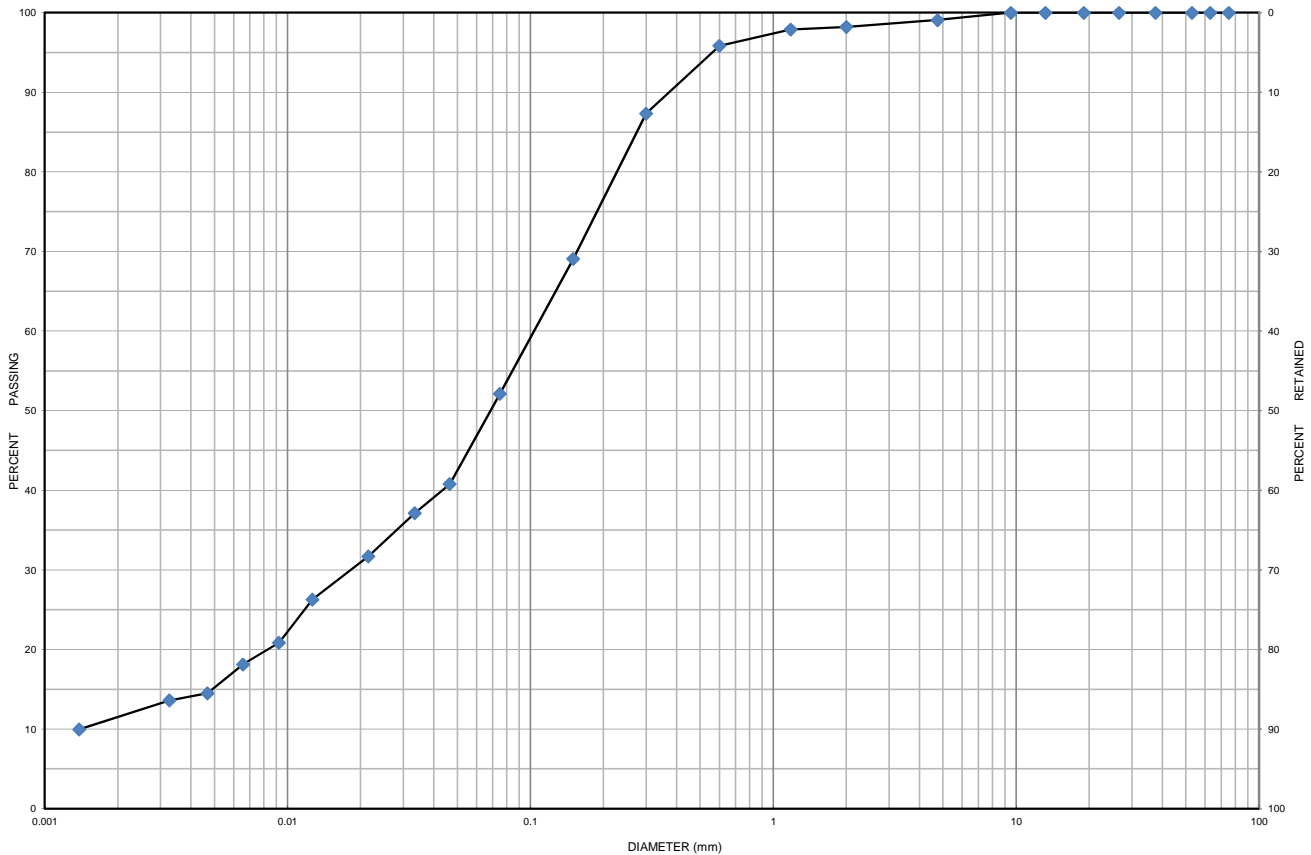

MIT SOIL CLASSIFICATION SYSTEM								
CLAY	SILT	FINE	MEDIUM	COARSE	FINE	MEDIUM	COARSE	BOULDERS
		SAND			GRAVEL			

Location	Sample No.	Depth	Gravel	Sand	Silt	Clay	Moisture
BH 108-17	SS 1	0 m to 0.6 m	1	47	52		19.5
Description		Classification	D ₆₀	D ₃₀	D ₁₀	C _u	C _c
Sand and Silt some Clay trace Gravel		SP-ML	0.110	0.019	0.0015	73.33	2.19

Issued By: *John Baird*
 (Senior Project Manager)

Date Issued: August 22, 2017